

A FORMAL MODEL OF PROGRAM DEPENDENCES  
AND ITS IMPLICATIONS FOR SOFTWARE TESTING,  
DEBUGGING, AND MAINTENANCE

Andy Podgurski<sup>†</sup>  
Lori A. Clarke<sup>‡</sup>

COINS Technical Report 89-116  
December 1989

<sup>†</sup>Department of Computer Engineering & Science  
10900 Euclid Avenue  
Case Western Reserve University  
Cleveland, Ohio 44106

<sup>‡</sup>*Software Development Laboratory*  
Computer and Information Science Department  
University of Massachusetts  
Amherst, Massachusetts 01003

*This paper to appear in*  
**IEEE Transactions on Software  
Engineering**

This work was supported by grants DCR-8404217 from the National Science Foundation, CCR-8704478 from the National Science Foundation with cooperation from the Defense Advanced Research Projects Agency (ARPA Order 6104).

# A Formal Model of Program Dependences and Its Implications for Software Testing, Debugging, and Maintenance

Andy Podgurski<sup>†</sup>  
Lori A. Clarke<sup>‡</sup>

<sup>†</sup>Computer Engineering & Science Department  
Case Western Reserve University  
Cleveland, Ohio 44106

<sup>‡</sup>Software Development Laboratory  
Computer & Information Science Department  
University of Massachusetts  
Amherst, Massachusetts 01003

## Abstract

A formal, general model of program dependences is presented and used to evaluate several dependence-based software testing, debugging, and maintenance techniques. Two generalizations of control and data flow dependence, called weak and strong syntactic dependence, are introduced and related to a concept called semantic dependence. Semantic dependence models the ability of a program statement to affect the execution behavior of other statements. It is shown, among other things, that weak syntactic dependence is a necessary but not sufficient condition for semantic dependence and that strong syntactic dependence is a necessary but not sufficient condition for a restricted form of semantic dependence that is finitely demonstrated. These results are then used to support some proposed uses of program dependences, to controvert others, and to suggest new uses.

## 1 Introduction

Program dependences are relationships, holding between program statements, that can be determined from a program's text and used to predict aspects of the program's execution behavior. There are two basic types of program dependences: "control dependences", which are features of a program's control structure, and "data flow dependences", which are features of a program's use of variables. Informally, a statement  $s$  is control dependent on the branch condition  $c$  of a

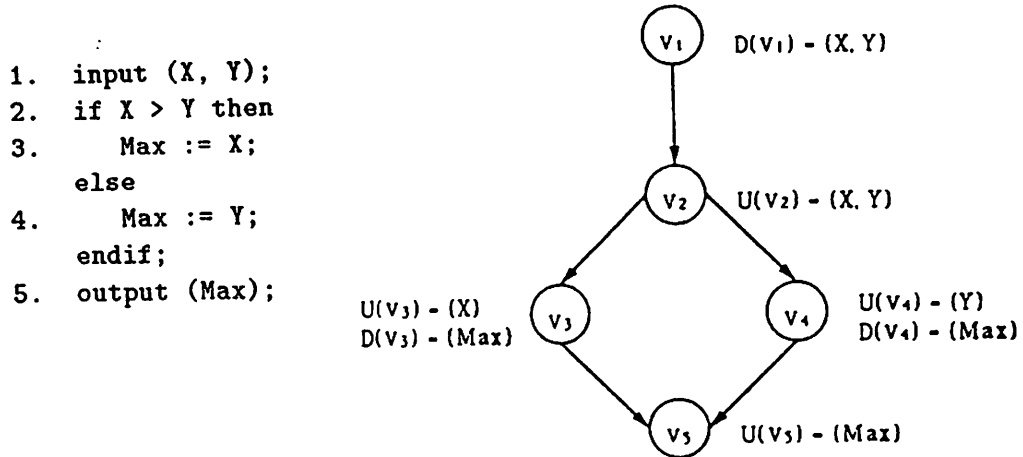

Figure 1: Max program and its def/use graph

conditional branch statement if the control structure of the program indicates that  $c$  potentially decides, via the branches it controls, whether  $s$  is executed or not. For example, in the program of Figure 1, statements 3 and 4 are control dependent on the branch condition at line 2. Informally, a statement  $s$  is data flow dependent on a statement  $s'$  if data potentially propagates from  $s'$  to  $s$  via a sequence of variable assignments. For example, in the program of Figure 1, statement 5 is data flow dependent on statement 1, since data potentially propagates from statement 1 to statement 5. **Dependence analysis**, the process of determining a program's dependences, combines traditional control flow analysis and data flow analysis [Aho86], and hence can be implemented efficiently.

Until recently, most proposed uses of program dependences have been justified only informally, if at all. Since program dependences are used for such critical purposes as software testing [Lask83, Kore87, Ntaf84, Rapp85], debugging [Berg85, Weis84], and maintenance [Reps89, Weis84], code optimization and parallelization [Ferr87, Padu86], and computer security [Denn77],<sup>1</sup> this informality is risky. This paper supplements other recent investigations of the semantic basis for the uses of program dependences [Cart89, Horw88a, Selk89] by presenting a formal, general model of program dependences and by using it to evaluate several dependence-based software testing, debugging,

<sup>1</sup>The term "dependence" is not used in all the references given.

and maintenance techniques. The results support certain proposed uses of program dependences, controvert others, and suggest new ones.

One example of our results involves the use of program dependences to find "operator faults" in programs. An operator fault is the presence of an inappropriate operator<sup>2</sup> in a program statement. For instance, accidental use of the multiplication operator "\*" instead of the addition operator "+" in the assignment statement "X := Y \* Z" results in an operator fault. It would be useful to be able to automatically detect and locate operator faults; unfortunately, as with many other semantic questions about programs, the question of whether a program contains an operator fault or not is undecidable. This paper shows, however, that there is an algorithm, in fact an *efficient* one, that detects *necessary conditions* for an operator fault at one statement to affect the execution behavior of another statement. These necessary conditions are expressed in terms of program dependences. Consequently, dependences can be used to help locate the statements that might be affected by an operator fault at a given statement.

To determine some of the implications of program dependences, we relate control and data dependence to a concept called "semantic dependence". Informally, a program statement  $s$  is semantically dependent on a statement  $s'$  if the semantics of  $s'$ , that is, the function computed by  $s'$ , potentially affects the execution behavior of  $s$ . The significance of semantic dependence is that it is a necessary condition for certain interstatement semantic relationships. For example, if  $s$  and  $s'$  are distinct statements, then  $s$  must be semantically dependent on  $s'$  for an operator fault at  $s'$  to affect the execution behavior of  $s$ . Similarly, some output statement must be semantically dependent on a statement  $s$  for the semantics of  $s$  to affect the output of a program.

Three main results are presented in this paper:

1. A generalization of control and data dependence, called "weak syntactic dependence", is a

---

<sup>2</sup>The term "operator" refers to both the predefined operators of a programming language and to user-defined procedures and functions.

necessary condition for semantic dependence

2. A commonly used generalization of control and data dependence, which we call “strong syntactic dependence”, is a necessary condition for semantic dependence only if the semantic dependence does not depend in a certain way on a program failing to terminate
3. Neither data flow, weak syntactic, nor strong syntactic dependence is a sufficient condition for semantic dependence

We use these results to evaluate several dependence-based testing, debugging, and maintenance techniques.

Section 2 defines some necessary terminology and Section 3 defines control, data, and syntactic dependence. Semantic dependence is informally defined in Section 4 and then related to syntactic dependence in Section 5. In Section 6, the implications of the results of Section 5 for software testing, debugging and maintenance are described. In Section 7, related work not already considered in Section 6 is surveyed. Section 8 presents a summary and discussion of possible future research directions. In Appendix A, the formal definition of semantic dependence is presented, and the proofs of the two most significant results of Section 5 are sketched.

## 2 Terminology

In this section we define control flow graphs, some dominance relations, and def/use graphs.

A **directed graph** or **digraph**  $G$  is a pair  $(V(G), A(G))$ , where  $V(G)$  is any finite set and  $A(G)$  is a subset of  $V(G) \times V(G) - \{(v, v) | v \in V(G)\}$ . The elements of  $V(G)$  are called **vertices** and the elements of  $A(G)$  are called **arcs**. If  $(u, v) \in A(G)$  then  $u$  is **adjacent to**  $v$  and  $v$  is **adjacent from**  $u$ ; the arc  $(u, v)$  is **incident to**  $v$  and **incident from**  $u$ . A **predecessor** of a vertex  $v$  is a vertex adjacent to  $v$ , and a **successor** of  $v$  is a vertex adjacent from  $v$ . The **indegree** of a vertex  $v$  is the number of predecessors of  $v$ , and the **outdegree** of  $v$  is the number of successors of  $v$ .

A walk  $W$  in  $G$  is a sequence of vertices  $v_1v_2 \cdots v_n$  such that  $n \geq 0$  and  $(v_i, v_{i+1}) \in A(G)$  for  $i = 1, 2, \dots, n - 1$ . The length of a walk  $W = v_1v_2 \cdots v_n$ , denoted  $|W|$ , is the number  $n$  of vertex occurrences in  $W$ . Note that a walk of length zero has no vertex occurrences; such a walk is called **empty**. A nonempty walk whose first vertex is  $u$  and whose last vertex is  $v$  is called a  **$u$ - $v$  walk**. If  $W = w_1w_2 \cdots w_m$  and  $X = x_1x_2 \cdots x_n$  are walks such that either  $W$  is empty,  $X$  is empty, or  $w_m$  is adjacent to  $x_1$ , then the concatenation of  $W$  and  $X$ , denoted  $WX$ , is the walk  $w_1w_2 \cdots w_mx_1x_2 \cdots x_n$ .

All the types of dependence considered in this paper are directly or indirectly defined in terms of a “control flow graph”, which represents the flow of control in a sequential, procedural program.

**Definition 1** *A control-flow graph  $G$  is a directed graph that satisfies each of the following conditions:*

1. *The maximum outdegree of the vertices of  $G$  is at most two<sup>3</sup>*
2.  *$G$  contains two distinguished vertices: the initial vertex  $v_I$ , which has indegree zero, and the final vertex  $v_F$ , which has outdegree zero*
3. *Every vertex of  $G$  occurs on some  $v_I$ - $v_F$  walk*

A vertex of outdegree two in a control flow graph is called a **decision vertex**, and an arc incident from a decision vertex is called a **decision arc**. The set of decision vertices of  $G$  is denoted  $V_{dec}(G)$ .

Here, the vertices of a control flow graph represent simple program statements (such as assignment statements and procedure calls) and also branch conditions, while the arcs represent possible transfers of control between these. The program’s entry point and exit point are represented by the initial vertex and final vertex, respectively. A decision vertex represents the branch condition

---

<sup>3</sup>This restriction is made for simplicity only.

of a conditional branch statement. The definition given here of a control flow graph is somewhat restricted, to simplify the presentation of results. This definition can be used to represent any procedural program, however, by employing straightforward representation conventions involving the use of dummy vertices and arcs.

The control flow graph of the program in Figure 1 is shown alongside the program; the annotations to this graph are explained subsequently.

The next three definitions are used in defining types of control dependence.

**Definition 2** *Let  $G$  be a control flow graph. A vertex  $u \in V(G)$  forward dominates a vertex  $v \in V(G)$  iff every  $v-v_F$  walk in  $G$  contains  $u$ ;  $u$  properly forward dominates  $v$  iff  $u \neq v$  and  $u$  forward dominates  $v$ .*

**Definition 3** *Let  $G$  be a control flow graph. A vertex  $u \in V(G)$  strongly forward dominates a vertex  $v \in V(G)$  iff  $u$  forward dominates  $v$  and there is an integer  $k \geq 1$  such that every walk in  $G$  beginning with  $v$  and of length  $\geq k$  contains  $u$ .*

In the control flow graph of Figure 1,  $v_5$  (strongly) forward dominates each vertex, whereas  $v_3$  and  $v_4$  forward dominate only themselves. In the control flow graph of Figure 2,  $v_5$  strongly forward dominates  $v_4$ , but  $v_6$  does not strongly forward dominate  $v_4$ , because there are arbitrarily long walks from  $v_4$  that do not contain  $v_6$ .

While control dependence has been defined in terms of forward dominance before [Denn77, Ferr87], the use of strong forward dominance for this purpose is apparently new.

We state the following theorem without proof.

**Theorem 1** *Let  $G$  be a control flow graph. For each vertex  $u \in (V(G) - \{v_F\})$ , there exists a proper forward dominator  $v$  of  $u$  such that  $v$  is the first proper forward dominator of  $u$  to occur on every  $u-v_F$  walk in  $G$ .*

```

1. input (N);
2. Fact := 1;
3. while not N = 0 loop
4.     Fact := Fact * N;
5.     N := N - 1;
6. end loop;
7. output ("The factorial is ");
8. output (Fact);

```

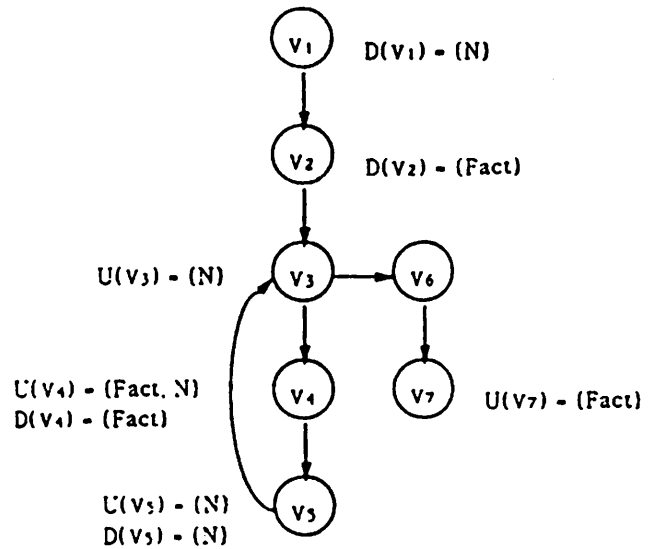

Figure 2: Factorial program and its def/use graph

The “immediate forward dominator” of a decision vertex  $d$  is the vertex where all walks leaving  $d$  first come together again. More formally:

**Definition 4** Let  $G$  be a control flow graph. The immediate forward dominator of a vertex  $v \in (V(G) - \{v_F\})$ , denoted  $ifd(v)$ , is the vertex that is the first proper forward dominator of  $v$  to occur on every  $v-v_F$  walk in  $G$ .

For example, in the control flow graph of Figure 1,  $v_5$  is the immediate forward dominator of  $v_2$ ,  $v_3$ , and  $v_4$ . In the control flow graph of Figure 2,  $v_6$  is the immediate forward dominator of  $v_3$ .

Data, syntactic, and semantic dependence are defined in terms of an annotated control flow graph called a “def/use graph”. For each vertex  $v$  in a def/use graph,  $D(v)$  denotes the set of variables defined (assigned a value) at the statement represented by  $v$ , and  $U(v)$  denotes the set of variables used (having their values referenced) at that statement. A def/use graph is similar to a program schema [Grei75, Mann74] and is essentially the program representation used in data flow analysis [Aho86].



**Definition 5** A def/use graph is a quadruple  $G = (G, \Sigma, D, U)$ , where  $G$  is a control flow graph,  $\Sigma$  is a finite set of symbols called variables, and  $D: V(G) \rightarrow \mathcal{P}(\Sigma)$ ,  $U: V(G) \rightarrow \mathcal{P}(\Sigma)$  are functions.<sup>4</sup>

The def/use graphs of the programs in Figures 1 and 2 are shown alongside the programs.

**Definition 6** Let  $G = (G, \Sigma, D, U)$  be a def/use graph, and let  $W$  be a walk in  $G$ . Then

$$D(W) = \bigcup_{v \in W} D(v)$$

For example, referring to the def/use graph of Figure 1,  $D(v_1v_2v_3v_5) = \{\text{Max}, X, Y\}$ .

As usual in the static analysis of programs, exactly what constitutes a variable, definition, or use is sometimes a subtle issue [Aho86]. In the model of computation we adopt (see Section 4), values are associated with the variables (names) in  $\Sigma$ , and a vertex  $v$  can interrogate only the values of variables in  $U(v)$  and modify only the values of variables in  $D(v)$ . In representing a program with our formalism, this means that if the statement represented by a vertex  $v$  reads or writes a storage element, or if this is *uncertain*, then a variable name that denotes the potentially accessed storage element should be included in  $U(v)$  or  $D(v)$ , respectively. When the accessed storage element cannot be determined until runtime, it is permissible to include either a distinct name for each storage element that might be accessed or one name denoting all such elements, provided the same representation is used consistently. When the same storage element is accessed via different names in the program, all of these names can be included or a single name can be used in place of them. These are the conventions usually adopted in static analysis, where, for example, an access through a pointer is often treated as an access to all the objects that might be pointed to, and an access to an array element is often treated as an access to the entire array. These conventions are conservative, in that they may indicate data flow that cannot actually occur, but are safe, in that they will not fail to indicate any data flow that does occur.

---

<sup>4</sup>We denote the power set (set of all subsets) of a set  $S$  by  $\mathcal{P}(S)$ .

### 3 Control, Data, and Syntactic Dependence

#### 3.1 Control Dependence

The concept of control dependence is used to model the effect of conditional branch statements on the behavior of programs. Control dependence is a property of a program's control structure alone, in that it can be defined strictly in terms of a control flow graph. Various formal and informal definitions of control dependence are given in the literature. Usually these are expressed in terms of "structured" control statements of a particular language or class of languages. Such definitions have limited applicability, because control statements vary across languages and because "unstructured" programs occur in practice. Indeed, even judicious use of the `goto` statement or the use of restricted branch statements such as Ada's `exit`, `raise`, and `return` statements can result in programs that are, strictly speaking, unstructured. It is therefore desirable to have a language-independent definition of control dependence that applies to both structured and unstructured programs. Two definitions that satisfy these requirements are those of "weak control dependence" and "strong control dependence".

Strong control dependence was originally defined in the context of computer security [Denn77]<sup>5</sup>, and this definition has been used by several authors [Kore87, Padu86, Weis84]. To our knowledge, it was the first graph-theoretic, language and structure-independent characterization of control dependence to appear in the literature.

**Definition 7** *Let  $G$  be a control flow graph, and let  $u, v \in V(G)$ . Then  $u$  is strongly control dependent on  $v$  iff there exists a  $v$ - $u$  walk  $vWu$  not containing the immediate forward dominator of  $v$ .*

For example, in the control flow graph of Figure 1, the immediate forward dominator of the decision vertex  $v_2$  is  $v_5$ ; therefore  $v_3$  and  $v_4$  are strongly control dependent on  $v_2$ . In the control flow graph

---

<sup>5</sup>In [Denn77] the concept is called "implicit information flow".

of Figure 2, the immediate forward dominator of the decision vertex  $v_3$  is  $v_6$ ; therefore  $v_3$ ,  $v_4$ , and  $v_5$  are strongly control dependent on  $v_3$ . Note that the statements that are strongly control dependent on the branch condition of a structured **if-then** or **if-then-else** statement are those in its “body”. The statements that are strongly control dependent on the branch condition of a structured **while** or **repeat-until** loop are the branch condition itself and the statements in the loop’s body.

Weak control dependence [Podg89] is a generalization of strong control dependence in the sense that every strong control dependence is also a weak control dependence.

**Definition 8** *Let  $G$  be a control flow graph, and let  $u, v \in V(G)$ . Vertex  $u$  is directly weakly control dependent on vertex  $v$  iff  $v$  has successors  $v'$  and  $v''$  such that  $u$  strongly forward dominates  $v'$  but does not strongly forward dominate  $v''$ ;  $u$  is weakly control dependent on  $v$  iff there is a sequence  $v_1, v_2, \dots, v_n$  of vertices,  $n \geq 2$ , such that  $u = v_1$ ,  $v = v_n$ , and  $v_i$  is directly weakly control dependent on  $v_{i+1}$  for  $i = 1, 2, \dots, n - 1$ .*

Informally,  $u$  is directly weakly control dependent on  $v$  if  $v$  has successors  $v'$  and  $v''$  such that if the branch from  $v$  to  $v'$  is executed then  $u$  is necessarily executed within a fixed number of steps, while if the branch from  $v$  to  $v''$  is taken then  $u$  can be bypassed or its execution can be delayed indefinitely.

The essential difference between weak and strong control dependence is that weak control dependence reflects a dependence between an exit condition of a loop and a statement outside the loop that may be executed after the loop is exited, while strong control dependence does not. For example, in the control flow graph of Figure 2,  $v_6$  is (directly) weakly control dependent on  $v_3$  (because  $v_6$  strongly forward dominates itself, but not  $v_4$ ), but not strongly control dependent on  $v_3$  (because  $v_6$  is the immediate forward dominator of  $v_3$ ). In addition,  $v_3$ ,  $v_4$ , and  $v_5$  are (directly) weakly control dependent on  $v_3$ , because each strongly forward dominates  $v_4$  but not  $v_6$ . The additional dependences of the weak control dependence relation are relevant to program behavior, because an exit condition of a loop potentially determines whether execution of the loop terminates.

The weak and strong control dependence relations for a control flow graph  $G$  can be computed in  $O(|V(G)|^3)$  time [Podg89].

### 3.2 Data Flow Dependence

Although several other types of data dependence are discussed in the literature, we require only data flow dependence [Ferr87, Padu86].

**Definition 9** Let  $G = (G, \Sigma, D, U)$  be a def/use graph, and let  $u, v \in V(G)$ . Vertex  $u$  is directly data flow dependent on vertex  $v$  iff there is a walk  $vWu$  in  $G$  such that  $(D(v) \cap U(u)) - D(W) \neq \emptyset$ ;  $u$  is data flow dependent on  $v$  iff there is a sequence  $v_1, v_2, \dots, v_n$  of vertices,  $n \geq 2$ , such that  $u = v_1$ ,  $v = v_n$  and  $v_i$  is directly data flow dependent on  $v_{i+1}$  for  $i = 1, 2, \dots, n - 1$ .

Note that if  $u$  is data flow dependent on  $v$  then there is a walk  $v_1W_1v_2W_2 \dots v_{n-1}W_{n-1}v_n$ ,  $n \geq 2$ , such that  $v = v_1$ ,  $u = v_n$ , and  $(D(v_i) \cap U(v_{i+1})) - D(W_i) \neq \emptyset$  for  $i = 1, 2, \dots, n - 1$ . Such a walk is said to demonstrate the data flow dependence of  $u$  upon  $v$ .

Referring to the def/use graph of Figure 1,  $v_3$  is directly data flow dependent on  $v_1$ , because the variable  $X$  is defined at  $v_1$ , used at  $v_3$ , and not redefined along the walk  $v_1v_2v_3$ ;  $v_5$  is directly data flow dependent on  $v_3$ , because the variable  $Max$  is defined at  $v_3$ , used at  $v_5$ , and not redefined along the walk  $v_3v_5$ . It follows that  $v_5$  is data flow dependent on  $v_1$ ; the walk  $v_1v_2v_3v_5$  demonstrates this dependence.

The direct data flow dependence relation for a control flow graph can be computed efficiently using a fast algorithm for the "reaching definitions" problem [Aho86]. The data flow dependence relation can then be efficiently computed using a fast algorithm for transitive closure [Aho74].

### 3.3 Syntactic Dependence

To evaluate uses of control and data dependence, it is necessary to consider *chains* of such dependences, that is, sequences of vertices in which each vertex except the last is either control dependent or data dependent on the next vertex. Informally, there is a “*weak syntactic dependence*” between two statements if there is a chain of data flow and/or *weak* control dependences between the statements, while there is a “*strong syntactic dependence*” between the statements if there is a chain of data flow dependences and/or *strong* control dependences between them. Weak syntactic dependence apparently has not been considered before in the literature; the notion of strong syntactic dependence is implicit in the work of several authors [Berg85, Denn77, Ferr87, Horw88a, Kore87, Padu86, Weis84].

**Definition 10** *Let  $G = (G, \Sigma, D, U)$  be a def/use graph, and let  $u, v \in V(G)$ . Vertex  $u$  is weakly syntactically dependent (strongly syntactically dependent) on vertex  $v$  iff there is a sequence  $v_1, v_2, \dots, v_n$  of vertices,  $n \geq 2$ , such that  $u = v_1$ ,  $v = v_n$ , and for  $i = 1, 2, \dots, n - 1$ , either  $v_i$  is weakly control dependent (strongly control dependent) on  $v_{i+1}$  or  $v_i$  is data flow dependent on  $v_{i+1}$ .*

Since the weak and strong control dependence and data flow dependence relations for a def/use graph can be computed efficiently, the weak and strong syntactic dependence relations can be computed efficiently by using a fast algorithm for transitive closure.

Referring to the def/use graph of Figure 2,  $v_6$  is weakly syntactically dependent on  $v_5$ , because  $v_6$  is weakly control dependent on  $v_3$  and  $v_3$  is data flow dependent on  $v_5$ ;  $v_5$  is strongly syntactically dependent on  $v_1$ , because  $v_5$  is strongly control dependent on  $v_3$  and  $v_3$  is data flow dependent on  $v_1$ . Note that  $v_6$  is not strongly syntactically dependent on  $v_5$ .

## 4 Semantic Dependence

Recall that, informally, a statement  $s$  is semantically dependent on a statement  $s'$  if the function computed by  $s'$  affects the execution behavior of  $s$ . In this section, a more precise but still informal description of semantic dependence is given. The formal definition is presented in Appendix A.

We first informally define the auxiliary terms necessary to define semantic dependence. A sequential procedural program can be viewed abstractly as an interpreted def/use graph. An interpretation of a def/use graph is an assignment of partial computable functions to the vertices of the graph. The function assigned to a vertex  $v$  is the one computed by the program statement that  $v$  represents; it maps values for the variables in  $U(v)$  to values for the variables in  $D(v)$  or, if  $v$  is a decision vertex, to a successor of  $v$ . An interpretation of a def/use graph is similar to an interpretation of a program schema [Grei75, Mann74]. An operational semantics for interpreted def/use graphs is defined in the obvious way, with computation proceeding sequentially from vertex to vertex along the arcs of the graph, as determined by the functions assigned to the vertices. A computation sequence of a program is the sequence of states (pairs consisting of a vertex and a function assigning values to all the variables in the program) induced by executing the program with a particular input. An execution history of a vertex  $v$  is the sequence whose  $i$ th element is the assignment of values held by the variables of  $U(v)$  just before the  $i$ th time  $v$  is visited during a computation. An execution history of a vertex in an interpreted def/use graph abstracts the “execution behavior” of a program statement.

A more precise description of semantic dependence can now be given:

**Definition 11** (*Informal*) *A vertex  $u$  in a def/use graph  $G$  is semantically dependent on a vertex  $v$  of  $G$  if there are interpretations  $I_1$  and  $I_2$  of  $G$  that differ only in the function assigned to  $v$ , such that for some input, the execution history of  $u$  induced by  $I_1$  differs from that induced by  $I_2$ .*<sup>6</sup>

---

<sup>6</sup>The formal definition of semantic dependence, given in Appendix A, contains conditions to ensure that a semantic

For example, if the branch condition  $X > Y$  in the program of Figure 1 were changed to  $X < Y$ , then the program would compute the *Min* function instead of the *Max* function. Hence, for all unequal values of  $X$  and  $Y$ , this change demonstrates that vertex  $v_5$  of the def/use graph of Figure 1 is semantically dependent on vertex  $v_2$ . As another example, if the statement  $N := N - 1$  in the program of Figure 2 were changed to  $N := N - 2$ , the while-loop would fail to terminate for the input  $N = 5$ , preventing statement 6 from executing. Hence, this change demonstrates that vertex  $v_6$  of the def/use graph of Figure 2 is semantically dependent on vertex  $v_5$ .

Note that a pair of execution histories that demonstrate a semantic dependence can differ in two ways: (a) the histories have corresponding entries that are unequal and (b) one history is longer than the other. Informally, the semantic dependence is said to be **finitely demonstrated** if either:

1. Condition (a) holds; or
2. Condition (b) is demonstrated by finite portions of the computation sequences that caused the execution histories

Semantic dependence demonstrated by a pair of *halting* computations is, of course, finitely demonstrated. For example, the semantic dependence of vertex  $v_5$  upon vertex  $v_2$  in the def/use graph of Figure 1 is finitely demonstrated, because the *Min* and *Max* functions are defined for all pairs of integers. The semantic dependence of vertex  $v_6$  upon vertex  $v_5$  in the def/use graph of Figure 2 is not finitely demonstrated, because the only way  $v_5$  can affect the execution behavior of  $v_6$  is by determining whether execution of the cycle  $v_3v_4v_5v_3$  terminates. Note that even *nonterminating* computations can finitely demonstrate semantic dependence, via their finite initial segments. For example, despite the fact that it makes the program fail to terminate, changing the statement  $N := N - 1$  in the program of Figure 2 to  $N := N - 2$  finitely demonstrates that vertex  $v_5$  of the pro-

---

dependence is not caused by the value of the function assigned to a vertex being undefined for some input. This is done to avoid trivial semantic dependences. When we informally refer to (the semantics of) one program statement affecting the execution behavior of another statement, this restriction is implied.

gram's def/use graph is semantically dependent on itself, because the change alters the argument to the second execution of statement 5 for the input  $N = 5$ .

## 5 Relating Semantic and Syntactic Dependence

In software testing, debugging, and maintenance, one is often interested in the following question:

When can a change in the semantics of a program statement affect the execution behavior of another statement?

This question is, however, undecidable in general. Dependence analysis, like data flow analysis, avoids problems of undecidability by trading precision for (efficient) decidability. During dependence analysis, programs are represented by def/use graphs, which contain limited semantic information but are easily analyzed. Dependence analysis allows semantic questions to be answered “approximately”, because a program’s dependences partially determine its semantic properties. To evaluate the usefulness of dependence analysis in “approximately” answering the question above, we frame the question in terms of def/use graphs, by asking “When is one statement semantically dependent on another?”. This leads to our main results.

(The proofs of Theorems 2 and 4 below are sketched in Appendix A. The proofs of Theorems 3 and 5 are given informally with the theorems. Formal versions of all these proofs are found in [Podg89].)

**Theorem 2** *Let  $G = (G, \Sigma, D, U)$  be a def/use graph, and let  $u, v \in V(G)$ . If  $u$  is semantically dependent on  $v$  then  $u$  is weakly syntactically dependent on  $v$ .*

It was shown in Section 4 that vertex  $v_6$  in the def/use graph of Figure 2 is semantically dependent on vertex  $v_5$ . This is reflected by the fact that  $v_6$  is weakly syntactically dependent on  $v_5$ , as shown in Section 3.3. However,  $v_6$  is not strongly syntactically dependent on  $v_5$ .



**Theorem 3** *Strong syntactic dependence is not a necessary condition for semantic dependence.*

The next theorem shows that strong syntactic dependence does have semantic significance. The theorem in fact justifies some informally-posed applications of dependence analysis (see Section 6).

**Theorem 4** *Let  $G = (G, \Sigma, D, U)$  be a def/use graph, and let  $u, v \in V(G)$ . If  $u$  is semantically dependent on  $v$  and this semantic dependence is finitely demonstrated then  $u$  is strongly syntactically dependent on  $v$ .*

It was shown in Section 4 that vertex  $v_5$  in the def/use graph of Figure 1 is semantically dependent on vertex  $v_2$  and that this semantic dependence is finitely demonstrated. This is reflected by the fact that  $v_5$  is strongly syntactically dependent on  $v_2$  ( $v_5$  is directly data flow dependent on  $v_3$ , which is strongly control dependent on  $v_2$ ).

**Theorem 5** *Neither direct data flow dependence nor data flow dependence is a sufficient condition for semantic dependence.*

In the def/use graph of Figure 3, vertex  $v_F$  is directly data flow dependent on vertex  $v_2$ . However,  $v_F$  is not semantically dependent on  $v_2$ . This is because no computation of any program with this def/use graph visits both  $v_2$  and  $v_F$ , since the “loop control variable”  $\sigma$  is not redefined in the cycle  $v_1v_2v_1$ .

**Corollary 1** *Neither weak nor strong syntactic dependence is a sufficient condition for semantic dependence.*

Figure 4 shows the dependence relations considered in this paper, ordered by set inclusion. There is an arrow from a relation  $R_1$  to a relation  $R_2$  if  $R_1 \subseteq R_2$ .

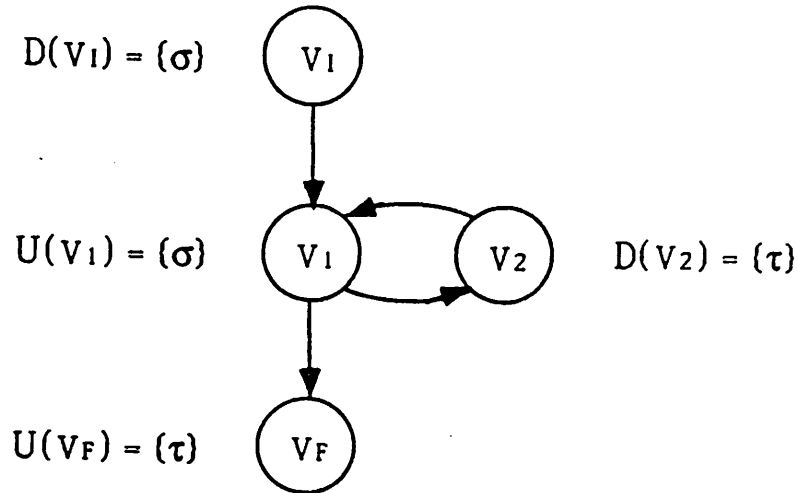

Figure 3: Direct data flow dependence without semantic dependence

## 6 Implications of the Results

The results of Section 5 support the following general conclusions about the use of dependence analysis to obtain information about relationships between program statements:

1. The absence of weak syntactic dependence between two statements precludes all relationships between them that imply semantic dependence
2. The absence of strong syntactic dependence between two statements does not necessarily preclude all relationships between them that imply (non finitely-demonstrated) semantic dependence
3. The absence of strong syntactic dependence between two statements precludes all relationships between them that imply finitely demonstrated semantic dependence
4. The presence of direct data flow dependence, data flow dependence, or weak or strong syntactic dependence between two statements does not necessarily indicate any relationship between the statements that implies semantic dependence

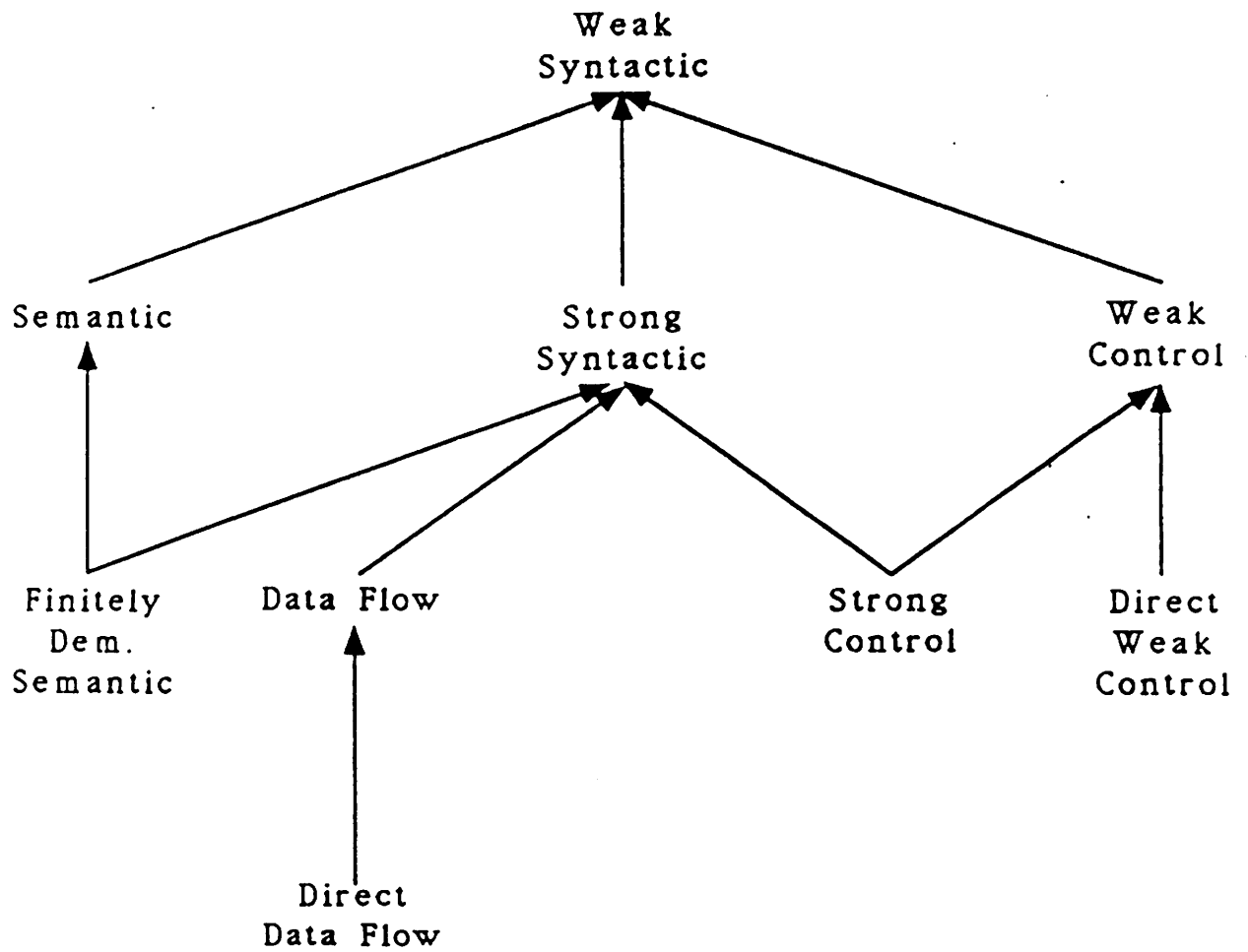

Figure 4: Relationships of dependence types

Conclusion 1 follows from Theorem 2; any relationship between two statements that implies semantic dependence also implies weak syntactic dependence. Conclusion 2 follows from Theorem 3 and Theorem 4; non finitely-demonstrated semantic dependence does not imply strong syntactic dependence. Conclusion 3 follows from Theorem 4; any interstatement relationship that implies finitely demonstrated semantic dependence also implies strong syntactic dependence. Finally, conclusion 4 follows from Theorem 5 and Corollary 1.

Note that conclusion 1 implies that the weak syntactic dependence relation for a program is an "upper bound" for (contains) any relation on the program's statements that implies semantic dependence. Similarly, conclusion 3 implies that the strong syntactic dependence relation for a program bounds any relation on the program's statements that implies finitely demonstrated semantic dependence. Since the syntactic dependences in a program can be computed efficiently, these bounds can be determined easily and used to narrow the search for statements having certain important relationships. For example, if an operator fault at a statement  $s$  affects the execution behavior of a statement  $s'$ , this demonstrates that  $s'$  is semantically dependent on  $s$ ; therefore, only those statements that are weakly syntactically dependent on  $s$  could be affected by an operator fault at  $s$ . Consequently, weak syntactic dependences can be used to help locate statements that can be affected by an operator fault at a given statement. Of course, whenever a relation  $R$  on the statements of a program implies finitely demonstrated semantic dependence, the strong syntactic dependence relation for the program is a "tighter" bound on  $R$  than the weak syntactic dependence relation is.

In the sequel, we use the results of Section 5 to evaluate the semantic basis for several proposed uses of dependences in testing, debugging, and maintenance and to suggest new uses. The results suggest that some proposed uses are mistaken, but provide partial justification, in terms of facilitating search, for other uses.

## 6.1 Dependence-Coverage Criteria

In software testing, a **dependence-coverage criterion** is a test-data selection rule based on “covering” or “exercising” certain program dependences. Several coverage criteria have been defined that call for exercising the data flow dependences in a program [Fran87, Lask83, Ntaf84, Rapp85]; these are called “data flow coverage criteria”. They require the execution of program walks<sup>7</sup> that demonstrate certain data flow dependences. One rationale for the data flow coverage criteria is that they facilitate the detection of incorrect variable definitions [Lask83, Rapp85], which may be caused by mistaken use of operators and/or variable names. Another is that they facilitate the detection of faults that cause missing and spurious data flow dependences [Lask83]. These two rationales are related, since an incorrect variable definition can cause missing or spurious data flow dependences. In Section 6.1.1 below we use the results of Section 5 to evaluate the use of dependence coverage criteria for the detection of those incorrect variable definitions that arise from operator faults. In Section 6.1.2, we use the results of Section 5 to evaluate the use of dependence coverage criteria for the detection of faults that cause missing and spurious dependences.

### 6.1.1 Detection of Operator Faults

The data flow coverage criteria address operator faults by exercising data flow dependences upon potentially faulty variable definitions. This may cause erroneous values produced by an operator fault to propagate, via the sequence of assignments represented by a data flow dependence, and produce an observable failure. The data flow coverage criteria differ with regard to the number and type of data flow dependences exercised and with regard to the number of walks executed that demonstrate a given dependence. For example:

- Rapps and Weyuker’s All-Defs criterion [Rapp85] exercises one direct data flow dependence, if possible, upon each variable definition in a program

---

<sup>7</sup>That is, sequences of statements corresponding to walks in a program’s control flow graph.

- Rapps and Weyuker's All-Uses and All-DU-Paths criteria [Rapp85] exercise all direct data flow dependences in a program
- Laski and Korel's Strategy II [Lask83] exercises all direct data flow dependences, but exercises them in combination
- For a fixed  $k$ , Ntafos's Required  $k$ -Tuples criterion [Ntaf84] exercises all chains of  $k$  direct data flow dependences; that is, all sequences of  $k + 1$  vertices such that each vertex in the sequence except the last is directly data flow dependent on the next

It is plausible that the propagation of erroneous values via data flow dependences alone is sufficiently common to make data flow coverage criteria worthwhile, even though, by conclusion 4, the fact that a statement  $s$  is data flow dependent on a faulty statement  $s'$  does not imply that an erroneous value propagates from  $s'$  to  $s$ . However, when an operator fault causes a conditional statement to make an incorrect branch, *control dependence* can be critical to the ability of the fault to affect the execution behavior of a particular statement. For example, changing the branch predicate  $X > Y$  in the program of Figure 1 to  $X < Y$  changes the number of times statement 3 is executed for the inputs  $X = 5, Y = 2$  because statement 3 is strongly control dependent on statement 2. Hence, no coverage criterion based only on exercising data flow dependences can, in general, exercise all the syntactic dependences associated with erroneous information flow produced by operator faults. Correspondingly, it is easily seen that data flow dependence is not a necessary condition for even finitely demonstrated semantic dependence.

Some of the data flow coverage criteria mentioned above, such as the All-Uses and Required  $k$ -Tuples criteria, incorporate limited forms of control dependence coverage. However, even these criteria do not exercise all syntactic dependences associated with the erroneous information flow produced by operator faults, because the types of syntactic dependences they exercise are still restricted. For any sequence of the letters "C" and "D", it is simple to construct an example of finitely demonstrated semantic dependence for which the corresponding strong syntactic dependence is re-

alized by only one chain of direct data flow dependences and direct strong control dependences, whose  $i$ th dependence is a direct strong control dependence (direct data flow dependence) if the  $i$ th letter of the sequence is "C" (is "D"). This means that, in general, almost arbitrarily complex chains of data flow and control dependences may have to be exercised to reveal operator faults.

As noted at the beginning of Section 6, it follows from conclusions 1 and 3 that syntactic dependences provide a nontrivial bound on the set of statements that can be affected by an operator fault at a given statement. One might think that to remedy the aforementioned weakness of the data flow coverage criteria it is only necessary to extend them to exercise *all* syntactic dependences upon a potentially faulty definition, instead of just data flow dependences. However, the number of tests required to adequately exercise all syntactic dependences can be impractically large, for the following reasons:

- The number of syntactic dependences in a program can be quadratic in the number of statements
- A given syntactic dependence may be demonstrated by many program walks (even infinitely many), only one of which is associated with erroneous information flow
- Erroneous information flow via a particular syntactic dependence may depend not only on which walk is executed, but also on the particular input used

At the very least, the bounds on erroneous information flow that are implied by a program's syntactic dependences *can* be used to filter out test data, selected without regard to the dependences, that cannot possibly reveal certain faults. More ambitiously, it may be possible to *base* test data selection on the determination of syntactic dependences, by analyzing individual syntactic dependences to determine which dependences, which walks demonstrating them, and which inputs executing these walks are most likely to be associated with erroneous information flow. Implementing this approach might require the development of techniques for more precise semantic analysis

of programs and for acquiring reliable statistical information about programmer error-making behavior.

### 6.1.2 Detection of Dependence Faults

Dependence analysis has something to say about other kinds of faults besides operator faults. A dependence fault is a fault causing different dependences to exist in an incorrect version of a program than in the correct program. A dependence fault may cause either "missing" or "spurious" dependences or both. A dependence is missing if it occurs in the correct program but not the faulty one; it is spurious if the reverse is true. For example, if the wrong variable name, say  $X$ , is used on the left hand side of an assignment statement, this makes every use of  $X$  reached by this definition of  $X$  spuriously data flow dependent on it. This fault may also cause data flow dependences upon definitions killed by the erroneous definition of  $X$  to be missing from the faulty program, although missing and spurious dependences do not always accompany each other. Dependence faults may also involve control dependence, as when a statement is erroneously placed in the body of a conditional branch statement, causing a spurious control dependence. In a sense, dependence faults are the complement of operator faults. Operator faults change only the semantics of a single statement; they do not change a program's def/use graph. Under certain assumptions, it can be shown that any fault that does change a program's def/use graph changes the program's syntactic dependences as well, and is therefore a dependence fault.

The data flow coverage criteria address dependence faults by exercising potentially spurious data flow dependences. To evaluate the soundness of this approach, it is necessary to relate the semantic and syntactic effects of dependence faults. The results of Section 5 do this for certain types of dependence faults. If a fault causes the function computed by a statement  $s$  to be erroneously relevant to the execution behavior of a statement  $s'$ , it follows from Theorems 2 and 4 that  $s'$  is syntactically dependent on  $s$ , since  $s'$  is semantically dependent on  $s$ . If this syntactic dependence exists only by virtue of the fault, then it is spurious. A fault may also cause the function computed



by a statement to be erroneously *irrelevant* to the execution behavior of another statement, with the result that a syntactic dependence between the statements is missing by virtue of the fault. By conclusions 1 and 3, if a statement  $s$  is not syntactically dependent on a statement  $s'$ , then the semantics of  $s'$  is irrelevant to the execution behavior of  $s$ . Thus, the presence or absence of syntactic dependences may be evidence of erroneous semantic relationships.

Exercising syntactic dependences, as the data flow coverage criteria do, may reveal when the function computed by one statement is erroneously relevant on the execution behavior of another statement, by exercising a spurious syntactic dependence associated with this fault and thereby eliciting the fault's effects. Of course, it is not sure to. Exercising syntactic dependences may also reveal when the function computed by a statement is erroneously irrelevant to the execution behavior of another statement, particularly if, as is often the case, missing syntactic dependences caused by this fault are accompanied by spurious ones. However, because the data flow coverage criteria exercise only restricted types of syntactic dependences, the results of Section 5 imply that these criteria do not necessarily exercise all missing and spurious syntactic dependences. In the absence of additional information, the only way to remedy this is to exercise every syntactic dependence in a program. For the reasons given in Section 6.1.1, we believe that this approach is untenable. Nevertheless, determination of syntactic dependences might be used to *guide* more discriminating methods for detecting dependence faults, in ways similar to those proposed in Section 6.1.1 for the detection of operator faults.

## 6.2 Anomaly Detection

A **program anomaly** is a syntactic pattern that is often evidence of a programming error, irrespective of a program's specification [Fosd76] — for example, a variable being used before it has been defined. Korel [Kore87] proposes using program dependences for the detection of “useless” statements, a type of anomaly detection. **Useless statements** are ones that cannot influence the output of a program and can be removed without changing the function the program computes.

Korel claims that a statement is useless if there is no output statement strongly syntactically dependent upon it.

Korel did not prove this informal claim. Nevertheless, conclusion 3 supports a version of it: if no output statement in a program is strongly syntactically dependent on  $s$ , then the semantics of  $s$  is irrelevant to the *values of variables* output by the program. This is because if a change to the semantics of  $s$  affected the value of a variable output at statement  $s'$ , then this would *finitely demonstrate* that  $s'$  was semantically dependent on  $s$ . A change to the semantics of a statement can affect the output of a program in ways that imply non finitely-demonstrated semantic dependence, however. By conclusion 2, non finitely-demonstrated semantic dependence might not be accompanied by strong syntactic dependence. In the factorial program of Figure 2, changing the branch condition of the while-loop to  $N = N$  causes the loop to execute forever; consequently, statement 6 is not executed. Thus vertex  $v_6$  of the program's def/use graph is semantically dependent on vertex  $v_3$ . However, this semantic dependence is not finitely demonstrated, and  $v_6$  is not strongly syntactically dependent on  $v_3$ . Hence, the fact that an output statement is not strongly syntactically dependent on a statement  $s$  does not imply that the semantics of  $s$  is irrelevant to the behavior of the output statement. However, if no output statement in a program is *weakly* syntactically dependent on  $s$  then, by conclusion 1, the semantics of  $s$  is irrelevant to the program's output.

### 6.3 Debugging and Maintenance

In both software debugging and maintenance, it is often important to know when the semantics of one statement can affect the execution behavior of another statement. In debugging, one attempts to determine what statement(s) caused an observed failure. In maintenance, one wishes to know whether a modification to a program will have unanticipated effects on the program's behavior; to determine this, it is helpful to know what statements are affected by the modified ones and what statements affect the modified ones. There are no general procedures for determining absolute answers to these questions, but dependence analysis can be used to answer them approximately.

In his work on program slicing, Weiser proposes that program dependences be used to determine the set of statements in a program — called a “slice” of the program — that are potentially relevant to the behavior of given statements [Weis79, Weis82, Weis84]. Weiser demonstrates how program slices can be used to locate faults when debugging. He claims that if an incorrect state is observed at a statement  $s$ , then only those statements that  $s$  is strongly syntactically dependent upon could have caused the incorrect state. He argues that by (automatically) determining those statements and then examining them the debugging process can be facilitated.

While most investigators who proposed uses for program dependences made no attempt to justify these uses rigorously, Weiser [Weis79] did recognize the need to do this for the use of dependences in his program slicing technique, and he attempted to provide such justification via both mathematical proofs and a psychological study. To this end, Weiser implicitly defined a type of semantic dependence and examined its relationship to syntactic dependence. Unfortunately, the mathematical part of Weiser’s work is flawed. In his dissertation [Weis79], Weiser states a theorem similar to Theorem 2.<sup>8</sup> In his attempted proof of this theorem, Weiser actually assumes, without proof, that strong syntactic dependence is a necessary condition for semantic dependence. Besides being very close to what Weiser is trying to prove, this assumption is false. Weiser does not address the issue of formal justification for slicing in his subsequent writings.

If a program failure observed at one statement is caused by an operator fault at another statement, it follows from conclusion 1 that the search for the fault can be facilitated by determining weak syntactic dependences, since the statement where the failure was observed is weakly syntactically dependent upon the faulty statement. If the failure implies finitely demonstrated semantic dependence, it follows from conclusion 3 that strong syntactic dependence can be used to help locate the fault. However, if the failure implies a semantic dependence that is not finitely demonstrated, then strong syntactic dependence cannot necessarily be used to locate the fault. This is illustrated by the example in Section 6.2. Hence, for locating operator faults, Weiser’s use of strong

---

<sup>8</sup>The theorem is stated in terms of Weiser’s problematic “color dominance” characterization of control dependence, which he abandoned in his later writings on slicing, in preference to strong control dependence.

syntactic dependence in slicing is justified only when the faults cause failures that finitely demonstrate semantic dependence. In his thesis [Weis79], Weiser does not restrict the type of semantic dependence he attempts to localize with slicing to be finitely demonstrated. In [Weis84], however, Weiser defines slicing for terminating programs only. In general, of course, faulty programs may fail to terminate, so this restriction limits the applicability of slicing.

The implications of conclusions 1–4 for maintenance are similar to those for debugging. If a modification involves only the semantics of a single statement, then, by conclusions 1 and 3, only those statements that are syntactically dependent on the statement to be modified could be affected by the modification. Similarly, only those statements that a modified statement is syntactically dependent on could be relevant to the behavior of the modified statement.

## 7 Other Related Work

In this section we briefly survey related work, not considered above, on the use of program dependences in testing, debugging, and maintenance.

Bergeretti and Carré [Berg85] present a variant of dependence analysis, called “information flow analysis”, that applies to structured programs. They suggest several uses for it, including testing and debugging. They define, by structural induction on the syntax of a programming language, three information flow relations that are similar to strong syntactic dependence.

Recently, several papers have investigated the semantic basis for proposed uses of program dependences [Cart89, Horw88a, Horw88b, Reps89, Selk89]. Some of these papers address the use of dependences in software debugging and maintenance. Horwitz *et al* [Horw88a] present a theorem that characterizes when two programs with the same dependences compute the same function. Reps and Yang [Reps89] use a version of this result to prove two theorems about program slicing. One of these states that a slice of a program computes the same function as the program itself on inputs for which the computations of both the program and its slice terminate. The second theorem states

that if a program is decomposed into slices, the program halts on any input for which all of the slices halt. The latter two theorems are used by Horwitz *et al* [Horw88b] to justify an algorithm for integrating versions of a program.

This paper differs in three respects from the other recent work on the semantic basis for the use of dependences. First, the other work does not address the concept of semantic dependence. Second, while the results in those papers are proved for a simple, structured programming language, we adopt a graph-theoretic framework for our results, similar to that in [Weis79], that makes them applicable to programs of any procedural programming language and to unstructured programs as well as structured ones. Third, this paper considers the semantic significance of both weak and strong control dependence, while the above papers consider only strong control dependence.

## 8 Conclusion

In summary, we have presented several results clarifying the significance of program dependences for the execution behavior of programs. We have shown that two generalizations of both control and data flow dependence, called weak and strong syntactic dependence, are necessary conditions for certain interstatement relationships involving the effects of program faults and modifications. This implies that weak and strong syntactic dependences, which can be computed efficiently, may be used to guide such activities as test data selection and program debugging. On the other hand, we have also shown that neither data flow nor syntactic dependence is a sufficient condition for the interstatement relationships in question. This result discourages the use of such dependences, in the absence of additional information, as evidence for the presence of these relationships. Finally, we have shown that strong syntactic dependence is not a necessary condition for some interstatement relationships involving program nontermination, and this suggests that some proposed uses of strong syntactic dependence in debugging and anomaly detection are unjustified.

There are several possible lines of further investigation related to the use of program dependences

in testing, debugging, and maintenance. For example, our results could be usefully extended to provide information about the effects of larger classes of faults and program modifications. Another possible line of investigation is the development of testing methods that exploit the fact that syntactic dependence bounds the statements that are affected by certain types of faults. For example, Morell [More84], Richardson and Thompson [Rich88], and Demillo *et al* [DeMi88] propose test data selection methods that might be adapted to do this, since their methods are based on determining conditions for erroneous program states to occur and then propagate to a program's output. A third possible line of investigation is the development of more sophisticated semantic analysis techniques to complement dependence analysis.

## A Appendix: Sketch of the Proofs of Theorems 2 and 4

The proofs of Theorems 2 and 4 are lengthy, so we only sketch them here; complete proofs are found in [Podg89].

To describe the proofs of Theorems 2 and 4, it is necessary to present the complete definition of semantic dependence. This definition uses some notation that we now informally define. An interpretation  $I$  of a def/use graph  $G = (G, \Sigma, D, U)$  is triple  $(\mathcal{D}, F, N)$ .  $\mathcal{D}$  is the set of objects which serve as the inputs, outputs, and intermediate results of a computation, and is called the **domain** of  $I$ .  $F$  is function that associates with every vertex  $v \in V(G)$  a partial recursive function  $F(v)$  that maps an assignment of values for the variables in  $U(v)$  to an assignment of values for the variables in  $D(v)$ .  $F$  represents the ability of a program statement to alter the value of variables.  $N$  is a function that associates with every decision vertex  $d \in V_{dec}(G)$  a function  $N(d)$  mapping an assignment of values for the variables in  $U(d)$  to a successor of  $d$ .  $N$  represents the ability of a branch condition of a conditional branch statement to determine the order of statement execution. The pair  $P = (G, I)$  is called a **program**. The computation sequence induced by executing  $P$  on an input  $d \in \mathcal{D}^\Sigma$  is denoted  $C_P(d) = \{(v_i, val_i)\}$ .<sup>9</sup> The execution history of  $v \in V(G)$  induced by

---

<sup>9</sup>The symbol  $\mathcal{D}^\Sigma$  denotes the set of functions from  $\Sigma$  into  $\mathcal{D}$ .

$C_{\mathbf{P}}(d)$  is denoted  $\mathcal{H}_{\mathbf{P}}(v, d)$ , and its  $i$ th element, if it exists, is denoted  $\mathcal{H}_{\mathbf{P}}(v, d)(i)$ .

We are now ready to present the formal definition of semantic dependence.

**Definition 12** *Let  $\mathbf{G} = (G, \Sigma, D, U)$  be a def/use graph, and let  $u, v \in V(G)$ . Vertex  $u$  is semantically dependent on vertex  $v$  iff there exist interpretations  $\mathbf{I}_1 = (\mathcal{D}, F_1, N_1)$  and  $\mathbf{I}_2 = (\mathcal{D}, F_2, N_2)$  of  $\mathbf{G}$  and an input  $d \in \mathcal{D}^\Sigma$  such that, letting  $\mathbf{P}_1 = (\mathbf{G}, \mathbf{I}_1)$  and  $\mathbf{P}_2 = (\mathbf{G}, \mathbf{I}_2)$ , both of the following conditions are satisfied:*

1. *For all  $w \in V(G) - \{v\}$ ,  $F_1(w) = F_2(w)$  and if  $w \in V_{dec}(G)$  then  $N_1(w) = N_2(w)$*
2. *Either of the following conditions is satisfied:*
  - (a) *There is some  $i \geq 1$  such that  $\mathcal{H}_{\mathbf{P}_1}(u, d)(i)$  and  $\mathcal{H}_{\mathbf{P}_2}(u, d)(i)$  are both defined but are unequal*
  - (b)  *$\mathcal{H}_{\mathbf{P}_1}(u, d)$  is longer than  $\mathcal{H}_{\mathbf{P}_2}(u, d)$ , and either  $C_{\mathbf{P}_2}(d) = \{(v_i, val_i)\}$  is infinite or it visits some vertex  $v_i$  from which  $u$  is unreachable*

$\mathbf{I}_1$ ,  $\mathbf{I}_2$ , and  $d$  are said to demonstrate that  $u$  is semantically dependent on  $v$ . If condition 1 holds and either condition 2(a) holds or both of the following conditions are true:

1.  $\mathcal{H}_{\mathbf{P}_1}(u, d)$  is longer than  $\mathcal{H}_{\mathbf{P}_2}(u, d)$
2.  $u$  is unreachable from some vertex of  $C_{\mathbf{P}_2}(d)$

then  $\mathbf{I}_1$ ,  $\mathbf{I}_2$ , and  $d$  are said to finitely demonstrate that  $u$  is semantically dependent on  $v$ .

The last part of condition 2(b) may be unintuitive. It requires that if a semantic dependence is demonstrated by the fact that one execution history is longer than another, then the computation sequence corresponding to the shorter history must be infinite or must contain a vertex from which the dependent vertex is unreachable. This requirement prevents a semantic dependence

from being demonstrated solely as the result of the divergence of a function assigned to a vertex. Such divergence can cause an execution history to be shorter than it would be if the divergence did not occur, by terminating a computation. The reason this possibility is disallowed is that if it were not, then each vertex would be semantically dependent on every other vertex from which it is reachable via an acyclic initial walk (path), trivializing the semantic dependence relation. If the shorter of two execution histories demonstrating a semantic dependence corresponds to either an infinite computation or to a computation containing a vertex from which the dependent vertex is unreachable, then divergence at a vertex either does not occur or is irrelevant to the demonstration of the dependence, respectively.

The proofs of Theorems 2 and 4 have the following basic form. First, a graph-theoretic structure is defined which represents the potential flow of data to a vertex  $v$  along an initial walk  $Wv$  in a def/use graph  $G$ . This structure is called the “context” of  $v$  with respect to  $Wv$ . It is then shown that in any execution of a program with def/use graph  $G$ , the arguments to an execution of  $v$  (that is, the values of the variables in  $U(v)$ ) are completely determined by its context. Next, necessary conditions for semantic dependence are given in terms of walks and contexts. These are obtained by analyzing the pair of possibly infinite “walks” executed by a pair of interpretations and an input that demonstrate semantic dependence. Finally, these conditions are used to prove Theorems 2 and 4. We now describe each of these steps in more detail.

The context  $CON(v, Wv)$  of a vertex  $v$  with respect to an initial walk  $Wv$  in a def/use graph  $G = (G, \Sigma, D, U)$  is a directed tree (technically an “in-tree” [Hara69]) that represents the cumulative flow of data to  $v$  along  $W$ .  $CON(v, Wv)$  contains a distinguished vertex of outdegree zero, called its sink. Each vertex of  $CON(v, Wv)$  is labelled with a vertex of  $G$  and each arc of  $CON(v, Wv)$  is labelled with a variable of  $\Sigma$ .  $CON(v, Wv)$  is defined inductively as follows. If  $W$  is empty then  $CON(v, Wv)$  consists of a single vertex labelled “ $v$ ”. Otherwise,  $CON(v, Wv)$  consists of

1. A sink  $s$  labelled “ $v$ ”



2. For each variable  $\sigma \in U(v)$  such that  $W = XuY$  with  $\sigma \in D(u) - D(Y)$ , a copy of  $CON(u, Xu)$  and an arc from its sink to  $s$  labelled " $\sigma$ ".

To see the significance of a context  $CON(v, Wv)$ , notice that if  $G$  represents a "real" program  $P$  then  $CON(v, Wv)$  is analogous to the set of symbolic values held by the variables of  $U(v)$  after the instruction sequence  $I(W)$  of  $P$  corresponding to  $W$  is *symbolically executed* [Clar81] (equivalently, executed under a Herbrand interpretation [Grei75, Mann74]). These symbolic values define the actual values of the variables in  $U(v)$ , as functions of the inputs to  $P$ , when  $I(W)$  is executed normally; hence, the symbolic values determine the actual ones. In the same way, the interpretation of the vertex labels of the context  $CON(v, Wv)$  determines the values of the variables in  $U(v)$  when  $W$  is executed for a given input and (abstract) interpretation of  $G$ . This is demonstrated formally by induction on the length of  $W$ .

To state necessary conditions for semantic dependence in terms of walks and contexts, it is necessary to introduce three auxiliary concepts: "hyperwalks", "consistency", and "reciprocal consistency". Since program computations may fail to terminate, it is necessary to consider infinite "walks" in def/use graphs; a hyperwalk in a def/use graph  $G$  is sequence of vertices that is either an ordinary walk or an infinite one. A hyperwalk  $W$  is consistent if there are no two occurrences of a decision vertex  $d$  in  $W$  that have the same context but are followed by different successors of  $d$ . This notion is analogous to the notion of path consistency in program schema theory [Grei75]. Because the context  $CON(d, Xd)$  determines the values of the variables in  $U(d)$  when  $Xd$  is executed, and hence determines the branch taken at  $d$ , an executable hyperwalk must be consistent.<sup>10</sup> Reciprocal consistency is similar to consistency, but is a necessary condition for a pair of hyperwalks to be executed by a pair of interpretations  $I_1$  and  $I_2$  that differ at only one vertex — such as a pair of interpretations that demonstrate semantic dependence. A pair of hyperwalks  $W$  and  $X$  is

---

<sup>10</sup>It can also be shown that every consistent hyperwalk is executed by some interpretation, using what is essentially a Herbrand interpretation of a def/use graph.

reciprocally  $v$ -consistent if

$$W = W_1uu'W_2 \text{ and } X = X_1uu''X_2 \text{ and } u' \neq u''$$

implies that either  $CON(u, W_1u) \neq CON(u, X_1u)$  or that  $CON(u, W_1u)$  contains a vertex labelled " $v$ ". Intuitively, if  $W$  and  $X$  are executed by  $I_1$  and  $I_2$ , respectively, the only way that  $CON(u, W_1u) = CON(u, X_1u)$  can hold is if  $v$  is the vertex whose interpretation differs between  $I_1$  and  $I_2$  and data flows from  $v$  to  $u$  via  $CON(u, W_1u)$  and  $CON(u, X_1u)$ .

Having defined contexts, hyperwalks, consistency, and reciprocal consistency, and having established their relevance to program execution, it is possible to establish necessary conditions for semantic dependence in terms of walks and contexts.

**Theorem 6** *Let  $G = (G, \Sigma, D, U)$  be a def/use graph and  $u, v \in V(G)$ . Then  $u$  is semantically dependent on  $v$  iff there exist initial hyperwalks  $W$  and  $X$  in  $G$  such that each of the following is true:*

1.  $W$  and  $X$  are algorithmically listable; and
2.  $W$  and  $X$  are consistent and reciprocally  $v$ -consistent; and
3. At least one of the following conditions holds:
  - (a)  $W = W_1uW_2$  and  $X = X_1uX_2$ , where  $u$  occurs the same number of times in  $W_1u$  as in  $X_1u$ , and where either  $CON(u, W_1u) \neq CON(u, X_1u)$  or  $CON(u, W_1u)$  contains a vertex other than its sink that is labelled " $v$ "
  - (b)  $W$  contains more occurrences of  $u$  than  $X$  does, and either  $X$  is infinite or  $X$  contains a vertex from which  $u$  is unreachable

It is interesting to note that these conditions are also *sufficient* for semantic dependence [Podg89], although this fact is not used in proving the results stated in Section 5. Condition 1

of Theorem 6, which means that there are some (possibly nonterminating) algorithms for listing  $W$  and  $X$ , is required for proving the sufficiency of the conditions but not for proving the results of Section 5; hence, we do not discuss it further.

To prove that the conditions of Theorem 6 are necessary for semantic dependence, one lets the hyperwalks  $W$  and  $X$  of the theorem be the walks executed by interpretations  $I_1$  and  $I_2$  of  $G$ , respectively, that, in conjunction with some input  $d$ , demonstrate that  $u$  is semantically dependent on  $v$ . Since these walks are executed by  $I_1$ ,  $I_2$ , and  $d$ , they must be consistent and reciprocally  $v$ -consistent, for the reasons given above; hence  $W$  and  $X$  satisfy condition 2 of Theorem 6. Note that condition 3 of Theorem 6 mirrors condition 2 of the definition of semantic dependence; however, the former condition is syntactic, whereas the latter is semantic. Let  $P_1 = (G, I_1)$  and  $P_2 = (G, I_2)$ .

Suppose that condition 2(a) of the definition of semantic dependence is satisfied:

There is some  $i \geq 1$  such that  $\mathcal{H}_{P_1}(u, d)(i)$  and  $\mathcal{H}_{P_2}(u, d)(i)$  are defined and unequal.

Let  $W = W_1uW_2$  and  $X = X_1uX_2$ , where  $u$  occurs exactly  $i$  times in  $W_1u$  and  $X_1u$ . Suppose  $v$  is not a vertex label in  $CON(u, W_1u)$ . Intuitively, then, data does not flow along  $W_1$  from  $v$  to the last occurrence of  $u$  in  $W_1u$ . Since  $v$  is the only vertex whose interpretation changes between  $I_1$  and  $I_2$ , and since the interpretation of the vertex labels of  $CON(u, W_1u)$  and  $CON(u, X_1u)$  determines the values of the variables in  $U(u)$  when  $W_1u$  and  $X_1u$ , respectively, are executed for a particular input,  $CON(u, W_1u) \neq CON(u, X_1u)$ . Otherwise, we would have  $\mathcal{H}_{P_1}(u, d)(i) = \mathcal{H}_{P_2}(u, d)(i)$ . If  $v$  is a vertex label in  $CON(u, W_1u)$ , then it is possible that  $CON(u, W_1u) = CON(u, X_1u)$ , since different data could flow from  $v$  to  $u$  via this context under  $I_1$  than under  $I_2$ . Thus, if condition 2(a) of the definition of semantic dependence is satisfied then condition 3(a) of Theorem 6 is also satisfied.

On the other hand, suppose that condition 2(b) of the definition of semantic dependence is satisfied:

$\mathcal{H}_{P_1}(u, d)$  is longer than  $\mathcal{H}_{P_2}(u, d)$ , and either  $C_{P_2}(d)$  is infinite or it visits a vertex

from which  $u$  is unreachable.

Then clearly condition 3(b) of Theorem 6 is satisfied. If condition 2(c) of the definition of semantic dependence is satisfied, then we may reverse the roles of  $W$  and  $X$  to obtain the same result.

Having established Theorem 6, we show that various subconditions of condition 3 of the theorem, taken together with condition 2, imply various types of syntactic dependence. We assume henceforth that condition 2 is satisfied by  $W$  and  $X$ .

It is easy to see that if condition 3(a) of Theorem 6 is satisfied by  $W$  and  $X$  because  $CON(u, W_1u)$  contains a vertex other than its sink that is labelled " $v$ ", then  $u$  is data flow dependent on  $v$ . This is because the head of an arc of  $CON(u, W_1u)$  is directly data flow dependent on its tail, as is clear from the definition of a context. The other subcondition of 3(a),  $CON(u, W_1u) \neq CON(u, X_1u)$ , implies that  $u$  is strongly syntactically dependent on  $v$ , but this is more difficult to see. The proof of this fact is a pivotal element in establishing the results of Section 5, since a generalization of condition 3(a) arises in considering condition 3(b).

Let us refer to the subcondition  $CON(u, W_1u) \neq CON(u, X_1u)$  of condition 3(a) in Theorem 6 as subcondition 3(a)'. The first step in showing that 3(a)' implies that  $u$  is strongly syntactically dependent on  $v$  is to show that 3(a)' implies that some vertex label of  $CON(u, W_1u)$  or  $CON(u, X_1u)$  is strongly control dependent on a decision vertex  $d$  having  $k$ th occurrences in  $W_1u$  and  $X_1u$  that are followed by different successors. Intuitively,  $d$  makes branches that cause  $CON(u, W_1u)$  and  $CON(u, X_1u)$  to differ. Since  $u$  is data flow dependent on the vertex labels of its contexts,  $u$  is strongly syntactically dependent on  $d$ . The existence of  $d$  is established by Lemma 1 below. Since  $W$  and  $X$  are reciprocally  $v$ -consistent, it follows either that  $d$  is data flow dependent on  $v$  or that the initial walks  $W_{1,1}d$  and  $X_{1,1}d$  of the lemma, which are shorter than  $W_1u$  and  $X_1u$ , themselves satisfy the hypothesis of the lemma. Since strong syntactic dependence is a transitive relation, it is evident that an inductive proof that  $u$  is strongly syntactically dependent on  $v$  can be framed using the lemma. The formalization of this proof is relatively straightforward; hence we focus on

the lemma and its proof.

**Lemma 1** *Let  $G = (G, \Sigma, D, U)$  be a def/use graph with  $u \in V(G)$ , and let  $W_1u$  and  $X_1u$  be initial walks in  $G$  containing the same number of occurrences of  $u$ . If  $CON(u, W_1u) \neq CON(u, X_1u)$ , then there is a vertex  $d \in V(G)$  such that a vertex-label of  $CON(u, W_1u)$  or  $CON(u, X_1u)$  is strongly control dependent on  $d$  and such that  $W_1u = W_{1,1}dd'W_{1,2}$  and  $X_1u = X_{1,1}dd''X_{1,2}$ , where  $d' \neq d''$  and  $d$  occurs equally often in  $W_{1,1}d$  and  $X_{1,1}d$ .*

This lemma is proved by assuming that no such vertex  $d$  exists, and then showing that this implies that  $W_1u$  and  $X_1u$  have a special structure which precludes  $u$  having different contexts with respect to them, which would of course be a contradiction. More precisely, we show, by induction on the length of the longer of  $W_1u$  and  $X_1u$ , that if there is no such vertex  $d$  then there are walks  $R_0, R_1, \dots, R_n, S_1, S_2, \dots, S_n$ , and  $T_1, T_2, \dots, T_n$  satisfying each of the following conditions:

1.  $W_1u = R_0S_1R_1S_2R_2 \cdots S_nR_n$
2.  $X_1u = R_0T_1R_1T_2R_2 \cdots T_nR_n$
3. For  $i = 1, 2, \dots, n$ ,  $R_i$  begins with  $ifd(r_{i-1})$ , where  $r_{i-1}$  is the last vertex of  $R_{i-1}$ , and  $ifd(r_{i-1})$  does not occur in  $S_i$  or  $T_i$
4. For  $i = 1, 2, \dots, n$ , the first vertex of  $S_iR_i$  is different from the first vertex of  $T_iR_i$

It follows that for  $i = 1, 2, \dots, n$ ,  $S_i$  and  $T_i$  consist of vertices that are strongly control dependent on  $r_{i-1}$ . It is not difficult to show, using induction and the transitivity of strong control dependence, that if a vertex label of  $CON(u, W_1u)$  or  $CON(u, X_1u)$  occurred in  $S_i$  or  $T_i$ , then we could let  $d$  in the statement of Lemma 1 be some  $r_j$ , where  $j < i$ , to obtain a contradiction. Intuitively, this means that the only part of  $W_1u$  that is relevant to the structure of  $CON(u, W_1u)$ , namely the subsequence  $R_0, R_1, \dots, R_n$ , is identical to the only part of  $X_1u$  that is relevant to the structure of  $CON(u, X_1u)$ . This implies that the two contexts are identical — which we show formally

by induction on the length of  $W_1u$ , exploiting the inductive definition of a context. Since this contradicts the hypothesis of the lemma, we conclude the lemma is true. This concludes our sketch of the proof that condition 3(a) of Theorem 6 implies that  $u$  is strongly syntactically dependent on  $v$ .

Suppose that condition 3(b) of Theorem 6 is satisfied by  $W$  and  $X$ . This condition is the disjunction of two subconditions, which we will denote  $3(b)'$  and  $3(b)''$ . Subcondition  $3(b)'$  is

$W$  contains more occurrences of  $u$  than  $X$  does, and  $X$  is infinite

while subcondition  $3(b)''$  is

$W$  contains more occurrences of  $u$  than  $X$  does, and  $X$  contains a vertex from which  $u$  is unreachable

We show that  $3(b)'$  implies, in conjunction with condition 2 of Theorem 6, that  $u$  is weakly syntactically dependent on  $v$  (it may or may not be strongly syntactically dependent on  $v$ ) and that  $3(b)''$  implies that  $u$  is strongly syntactically dependent on  $v$ . We now sketch these proofs, beginning with that of the second result.

Suppose that subcondition  $3(b)''$  is satisfied. To deal with this case, we prove Lemma 2 below. Note that if we identify the vertex  $u$  of  $3(b)''$  with the vertex  $w$  of the lemma and let the walks  $Yw$  and  $Zx$  of the lemma be appropriate prefixes of  $W$  and  $X$ , respectively, then the lemma applies. The reciprocal  $v$ -consistency of  $W$  and  $X$  implies that either the vertex  $d$  of the lemma is data flow dependent on  $v$ , which implies that  $u$  is strongly syntactically dependent on  $v$ , or the walks  $Y_1d$  and  $Z_1d$  of the lemma satisfy the hypothesis of Lemma 1. Since  $Y_1d$  and  $Z_1d$  are shorter than  $Yw$  and  $Zx$ , respectively, this allows us to frame an inductive proof that  $u$  is strongly syntactically dependent on  $v$ , similar to that discussed with regard to subcondition  $3(a)'$  of Theorem 6.

**Lemma 2** *Let  $G$  be a control flow graph,  $w, x \in V(G)$ , and  $Yw$  and  $Zx$  walks in  $G$ . If (1)  $w$  is*

unreachable from  $x$ , (2)  $Yw$  and  $Zx$  begin with the same vertex, and (3)  $w$  has more occurrences in  $Yw$  than in  $Zx$ , then there is a vertex  $d$  such that (a)  $w$  is strongly control dependent on  $d$ , (b)  $Yw = Y_1dd'Y_2$ , and (c)  $Zx = Z_1dd''Z_2$ , where  $d' \neq d''$  and  $d$  has the same number of occurrences in  $Y_1d$  as in  $Z_1d$ .

The proof of this lemma implicitly demonstrates that if no such vertex  $d$  exists, then  $Yw$  and  $Zx$  have a special structure similar to that discussed above in regard to the proof of Lemma 1, although the proof of Lemma 2 proceeds directly instead of by contradiction. It is shown that if  $R$  is the longest common prefix of  $Yw$  and  $Zx$  then  $Yw = RY'w$  and  $Zx = RZ'x$ , where the first vertex of  $Y'w$  is different from that of  $Z'x$ . If  $w$  is strongly control dependent on the last vertex  $r$  of  $R$  then we may let  $d = r$ . Suppose that  $w$  is not strongly control dependent on  $r$ . It is shown that in this case  $ifd(r)$ , the immediate forward dominator of  $r$ , occurs in both  $Y'w$  and  $Z'x$ . Thus,  $Y'w = Y_1ifd(r)Y_2$  and  $Z'x = Z_1ifd(r)Z_2$ , where  $ifd(r)$  does not occur in  $Y_1$  or  $Z_1$ . Each vertex in  $Y_1$  and  $Z_1$  is strongly control dependent on  $r$ , so  $w$  cannot occur in either walk. This implies that there are more occurrences of  $w$  in  $ifd(r)Y_2$  than in  $ifd(r)Z_2$ . Since these walks satisfy the hypothesis of Lemma 2 and are shorter than  $Yw$  and  $Zx$ , respectively, we may frame an inductive proof of the lemma. By assuming the truth of the lemma for  $ifd(r)Y_2$  and  $ifd(r)Z_2$ , we conclude that  $ifd(r)Y_2 = S_1dd'S_2$  and  $ifd(r)Z_2 = T_1dd''T_2$ , where  $d \neq d''$  and  $d$  has the same number of occurrences in  $S_1d$  as in  $T_1d$ . The vertex  $d$  must also have the same number of occurrences  $RY_1S_1d$  as in  $RZ_1T_1d$  — for otherwise  $d$  occurs in  $Y_1$  or  $Z_1$  and so is strongly control dependent on  $r$ , which, by the transitivity of strong control dependence, implies that  $w$  is strongly control dependent on  $r$ .

To demonstrate the implications of subcondition 3(b)' of Theorem 6 it is necessary to introduce a new type of control dependence, called "exit dependence". The exit dependence relation represents the potential ability of a loop exit condition to determine whether a statement outside the loop is executed, by determining whether the loop terminates.

**Definition 13** Let  $G$  be a control flow graph, and let  $u, v \in V(G)$ . Vertex  $u$  is exit dependent

on vertex  $v$  iff there is a cycle  $C$  and a walk  $vWu$  in  $G$  such that  $v$  occurs in  $C$  and such that  $Wu$  is vertex-disjoint from  $C$ .

For example, in the def/use graph of Figure 2, vertex  $v_7$  is exit dependent on vertex  $v_3$ , as can be seen by letting  $u = v_7$ ,  $v = v_3$ ,  $C = v_3v_4v_5v_3$ , and  $uWv = v_3v_6v_7$ .

In [Podg89], it is shown that the weak control dependence relation of a control flow graph  $G$  is the transitive closure of the union of the exit dependence and strong control dependence relations of  $G$ . That is, the existence of a chain of exit dependences and strong control dependences from  $u$  to  $v$  indicates  $u$  is weakly control dependent on  $v$ , and conversely if  $u$  is weakly control dependent on  $v$  then such a chain exists. We very briefly describe the basis for this result. A preliminary step in establishing the result is showing that the strong control dependence relation is the transitive closure of the "direct strong control dependence" relation.

**Definition 14** Let  $G$  be a control flow graph, and let  $u, v \in V(G)$ . Vertex  $u$  is directly strongly control dependent on vertex  $v$  iff  $v$  has successors  $v'$  and  $v''$  such that  $u$  forward dominates  $v'$  but  $u$  does not forward dominate  $v''$ .

The similarity between this definition and that of direct weak control dependence is obvious, as is the similarity between the definition of weak control dependence and the characterization of strong control dependence in terms of direct strong control dependence. The difference between direct weak and direct strong control dependence, and therefore between weak and strong control dependence, is that  $u$  can be directly weakly control dependent on  $v$  because there are infinite walks not containing  $u$  that begin with one successor of  $v$  but no such walks that begin with the other successor. It can be shown that any such infinite walk contains a cycle that demonstrates that  $u$  is exit dependent on either  $v$  or some vertex strongly control dependent on  $v$ .

Suppose now that subcondition 3(b)' of Theorem 6 is satisfied by  $W$  and  $X$ , along with condition 2 of that theorem. The following lemma, which is proved by an argument similar to those used



to establish Lemmas 1 and 2, shows that subcondition 3(b)' reduces to condition 3(a) of Theorem 6.

**Lemma 3** *Let  $G$  be a control flow graph with  $w \in V(G)$ , and let  $Yw$  and  $Z$  be hyperwalks in  $G$  such that  $Yw$  and  $Z$  begin with the same vertex,  $w$  has more occurrences in  $Yw$  than in  $Z$ ,  $Z$  is infinite, and  $w$  is reachable from every vertex in  $Z$ . Then there is a vertex  $d \in V(G)$  such that each of the following is true:*

1. *Either  $w$  is strongly control dependent on  $d$ ,  $w$  is exit dependent on  $d$ , or there is a vertex  $x \in V(G)$  such that  $x$  is strongly control dependent on  $d$  and such that  $w$  is exit dependent on  $x$*
2.  *$Yw = Y_1dd'Y_2$  and  $Z = Z_1dd''Z_2$ , where  $d' \neq d''$  and  $d$  has the same number of occurrences in  $Y_1d$  as in  $Z_1d$*

Because the weak syntactic dependence relation for  $G$  is the transitive closure of the union of the exit dependence and strong control dependence relations for  $G$ , the vertex  $w$  of the lemma is weakly control dependent on the vertex  $d$  whose existence the lemma asserts. Suppose that  $w$  is identified with the vertex  $u$  of subcondition 3(b)', and that the lemma is applied to  $Z = X$  and a prefix of  $Yw$  of  $W$  that contains more occurrences of  $u$  than  $X$  does. Then either the vertex  $d$  whose existence the lemma asserts is data flow dependent on  $v$  and therefore  $u$  is weakly syntactically dependent on  $v$ , or the walks  $Y_1d$  and  $Z_1d$  satisfy the hypothesis of Lemma 1. Thus, using the fact that strong syntactic dependence is transitive and implies weak syntactic dependence, we can frame an inductive proof that  $u$  is weakly syntactically dependent on  $v$ .

## References

- [Aho74] Aho, A. V., Hopcroft, J. E., and Ullman, J.D. *The Design and Analysis of Computer Algorithms*. Addison-Wesley, Reading, Massachusetts 1974.

- [Aho86] Aho, A. V., Sethi, R., and Ullman, J.D. *Compilers: Principles, Techniques, and Tools*. Addison-Wesley, Reading, Massachusetts 1986.
- [Berg85] Bergeretti, J. F. and Carré, B. A. Information-flow and data-flow analysis of while-programs. *ACM Transactions on Programming Languages and Systems*, Vol. 7, No. 1, January 1985, pp. 37–61.
- [Cart89] Cartwright, R. and Felleisen, M. The semantics of program dependence. *Proceedings of the SIGPLAN '89 Conference on Programming Language Design and Implementation*, Association for Computing Machinery, New York, 1989, pp. 13–27.
- [Clar81] Clarke, L. A. and Richardson, D. J. Symbolic evaluation methods – implementations and applications. *Computer Program Testing*, B. Chandrasekaran and S. Radicchi Eds., North Holland, 1981, pp 65–102.
- [DeMi88] DeMillo, R.A., Guindi, D.S., King, K.N., McCracken, W.M., and Offutt, A.J. An extended overview of the Mothra software testing environment. *Proceedings of the Second Workshop on Software Testing, Verification and Analysis*, Banff, Alberta, July 1988, pp. 142–151.
- [Denn77] Denning, D. E. and Denning, P. J. Certification of programs for secure information flow. *Communications of the ACM*, Vol. 20, No. 7, July 1977, pp. 504–513.
- [Ferr87] Ferrante, J., Ottenstein, K. J., and Warren, J. D. The Program Dependence Graph and its use in optimization. *ACM Transactions on Programming Languages and Systems*, Vol. 9, No. 5, July 1987, pp 319–349.
- [Fosd76] Fosdick, L. D. and Osterweil, L. J. Data flow analysis in software reliability. *ACM Computing Surveys*, Vol. 8, No. 3, September 1976, pp. 306–330.
- [Fran87] Frankl, P. G. The use of data flow information for the selection and evaluation of software test data. Doctoral Thesis, New York University, New York, 1987.

- [Grei75] Greibach, S. A. *Theory of Program Structures: Schemes, Semantics, Verification*. Springer-Verlag, Berlin, 1975.
- [Hara69] Harary, Frank. *Graph Theory*. Addison-Wesley, Reading, Massachusetts, 1969.
- [Horw88a] Horwitz, S., Prins, J., and Reps, T. On the adequacy of program dependence graphs for representing programs. *Proceedings of the Fifteenth ACM Symposium on Principles of Programming Languages*, Association for Computing Machinery, New York, 1988, pp. 146-157.
- [Horw88b] Horwitz, S., Prins, J., and Reps, T. Integrating non-interfering versions of programs. *Proceedings of the Fifteenth ACM Symposium on Principles of Programming Languages*, Association for Computing Machinery, New York, 1988, pp. 133-145.
- [Kore87] Korel, B. The program dependence graph in static program testing. *Information Processing Letters* 24, January 1987, pp. 103-108.
- [Lask83] Laski, J. W. and Korel, B. A data flow oriented program testing strategy. *IEEE Transactions on Software Engineering*, Vol. SE-9, No. 3, May 1983, pp. 347-354.
- [Mann74] Manna, Z. *Mathematical Theory of Computation*. McGraw-Hill, New York, 1974.
- [More84] Morell, L. J. A theory of error-based testing. Doctoral thesis, University of Maryland, College Park, Maryland, 1984.
- [Ntaf84] Ntafos, S. C. On Required Element Testing. *IEEE Transactions on Software Engineering*, Vol. SE-10, No. 6, November 1984, pp. 795-803.
- [Padu86] Padua, D. A. and Wolfe, M. J. Advanced compiler optimizations for supercomputers. *Communications of the ACM*, Vol. 29, No. 12, December 1986, pp. 1184-1201.
- [Podg89] Podgurski, Andy. The significance of program dependences for software testing, debugging, and maintenance. Doctoral dissertation, Computer and Information Science Department, University of Massachusetts, Amherst, 1989.

- [Rapp85] Rapps, S. and Weyuker, E. J. Selecting software test data using data flow information. *IEEE Transactions on Software Engineering*, Vol. SE-11, No. 4, April 1985, pp. 367-375.
- [Reps89] Reps, T. and Yang, W. The semantics of program slicing. Technical report, University of Wisconsin-Madison, 1989.
- [Rich88] Richardson, D. J. and Thompson, M. C. The RELAY model of error detection and its application. *Proceedings of the Second Workshop on Software Testing, Verification, and Analysis*, IEEE Computer Society, Los Angeles, California, 1988.
- [Selk89] Selke, R. P. A rewriting semantics for program dependence graphs. *Conference Record of the 16th ACM Symposium on Principles of Programming Languages*, Association for Computing Machinery, New York, 1989, pp. 12-24.
- [Weis79] Weiser, M. Program slices: formal, psychological, and practical investigations of an automatic program abstraction method. Doctoral dissertation, University of Michigan, Ann Arbor, Michigan, 1979.
- [Weis82] Weiser, M. Programmers use slices when debugging. *Communications of the ACM*, Vol. 25, No. 7, July 1982, pp. 446-452.
- [Weis84] Weiser, M. Program slicing. *IEEE Transactions on Software Engineering*, Vol. SE-10, No. 4, July 1984, pp. 352-356.