

**ACTA: A FRAMEWORK FOR  
SPECIFYING AND REASONING  
ABOUT TRANSACTION STRUCTURE  
AND BEHAVIOR**

**P. K. Chrysanthis and K. Ramamritham  
Department of Computer and Information Science  
University of Massachusetts  
Amherst, MA 01003**

**COINS Technical Report 89-119  
Replaces COINS TR 89-27**

# ACTA: A Framework for Specifying and Reasoning about Transaction Structure and Behavior \*

Panayiotis K. Chrysanthis  
Krithi Ramamritham

Department of Computer and Information Science  
University of Massachusetts  
Amherst MA. 01003

## Abstract

Recently, a number of extensions to the traditional transaction model have been proposed to support new information-intensive applications such as CAD/CAM and software development. However, these extended models capture only a subset of interactions that can be found in such applications, and represent only some of the points within the spectrum of interactions possible in competitive and cooperative environments.

*ACTA* is a formalizable framework developed for characterizing the whole spectrum of interactions. The ACTA model is *not* yet another transaction model, but is intended to unify the existing models. ACTA allows for specifying the *structure* and the *behavior* of transactions as well as for reasoning about the concurrency and recovery properties of the transactions. In ACTA, the semantics of interactions are expressed in terms of transactions' effects on the commit and abort of other transactions and on objects' state and concurrency status (i.e., synchronization state). Its ability to capture the semantics of previously proposed transaction models is indicative of its generality. The reasoning capabilities of this framework have also been tested by using the framework to study the properties of a new model that is derived by combining two existing transaction models.

---

\*This material is based upon work supported by the National Science Foundation under grant CCR-8500332

# 1 Introduction

The need to support *complex information systems* emerges from the demands of new and complex applications, such as CAD/CAM, software development environments, object-oriented databases, stock trading databases, and distributed operating systems. These systems are typically distributed and object based, i.e., designed in terms of an object-oriented paradigm. The ability of transactions to mask the effects of concurrency and failures makes them appropriate building blocks for these complex systems. Although powerful, the transaction model found in traditional database systems [5, 7] is found lacking in *functionality* and *efficiency* when used for these new applications. Efficiency is of particular importance considering the throughput demands placed on these complex information systems. In terms of functionality, traditional transactions were assumed to be short-lived and were targeted for competitive environments. Activities in complex information systems tend to access many objects, involve lengthy computations, and are interactive, i.e., pause for input from the user. Even in those cases where activities with such characteristics can be modeled as traditional transactions, they degrade the system performance due to increased data contention, thus failing to meet the high throughput demands. Furthermore, endless and collaborating activities which are often found in these systems, cannot be captured by traditional transactions due to serializability as the correctness requirement. Therefore, the need to capture reactive (endless), open-ended (long-lived) and collaborative (interactive) activities found in the new applications suggests the need for more cooperative models. Broadly speaking, whether a system is characterized as competitive or cooperative depends on how *interactions* among activities in the system are viewed: in competitive environments, interactions are curtailed whereas they are promoted in cooperative environments.

In order to fill this need for more flexible transaction models, various extensions to the traditional model have been proposed, referred to herein as *complex transactions*, which can support the implementation of efficient systems. For example, Nested Transactions [12] have been proposed in the context of distributed languages to handle the problem of partial failures. Nested Transactions support only hierarchical computations similar to the ones that result from procedure calls. Recoverable Communicating Actions [19] which support arbitrary computation topologies, have been proposed in the context of distributed operating systems where interactions are more complex. Cooperative Transactions [3], Split Transactions [15] and Transaction Groups [6, 18] have also been suggested for capturing the

interactions found in the new applications. Irrespective of how successful these extended transaction models are in supporting the systems that they were intended for, they merely represent points within the spectrum of interactions possible within competitive and cooperative environments. Therefore, they can capture only a subset of the interactions to be found in any complex information system.

While it is tempting to develop new transaction models that cover some of the remaining points in the spectrum, any such work will by necessity be ad hoc and not general. What will be better is to study the nature of transactions as such and develop a conceptual framework in which it will be possible to specify the effects of complex transactions and then reason about their properties.

We have developed such a comprehensive transaction framework, called *ACTA*<sup>1</sup>, for characterizing the whole spectrum of interactions. In ACTA, the semantics of interactions are expressed in terms of transactions' effects on the commit and abort of other transactions and on objects' state and concurrency status (i.e., synchronization state). ACTA allows for specifying the *structure* and the *behavior* of transactions as well as for reasoning about the concurrency and recovery properties of the transactions. *Structure* refers, for example, to the nesting structure of a transaction, and *behavior* refers to the operations invoked by a transaction.

The ACTA model is *not* yet another transaction model, but is intended to unify the existing models. Its ability to capture the semantics of previously proposed transaction models is indicative of its generality. The reasoning capabilities of this framework have also been tested by using the framework to study the properties of a new transaction model, called *Nested-Split Transactions*, that is derived by combining the Nested and Split Transaction models.

In Section 2, we examine the characteristics of complex transactions. In Section 3, we present ACTA, our proposed comprehensive transaction framework and discuss the intuition underlying the model. Section 4 illustrates the use of the framework by applying it to model four existing transactions models. In the same section, the reasoning capabilities of the framework are demonstrated by studying the properties of the Nested-Split transaction model. Section 5 concludes with a summary and discusses future steps.

---

<sup>1</sup>ACTA means *actions* in Latin.

## 2 Complex Transactions: Definition and Issues

Traditional transactions are based on the notion of *atomicity* and thus are often referred to as *atomic transactions*. Atomicity is characterized by two properties: failure atomicity and serializability. *Failure atomicity* means that either all or none of the transaction's operations are performed. *Serializability* means that concurrent transactions execute without any interference as though they were executed in some serial order. However, these properties combine several important notions such as:

1. *Visibility*, referring to the ability of one transaction to see the results of another transaction *while* it is executing.
2. *Permanence*, referring to the ability of a transaction to record its results in the database.
3. *Recovery*, referring to the ability, in the event of failure, to take the database to some state that is considered correct.
4. *Consistency*, referring to the correctness of the state of the database that a committed transaction produces.

The flexibility of a given transaction model depends on the way these four notions are combined. Thus, these notions have to be revisited in order to understand the properties of complex transactions and to decide on the mechanisms for supporting them. For example, visibility does not always have to be curtailed, permanence need not require all the results to be recorded in the database, recovery does not imply the complete restoration of the state and consistency does not necessarily require serializability.

Complex transactions have properties which relate to the above notions. Generally, *complex transactions* can be said to consist of either a set of operations on objects or a set of complex transactions. This recursive formulation implies that a complex transaction may exhibit a rich and complex internal structure. In contrast, traditional transactions have a flat single level structure. In this sense, the base case in this recursive definition of complex transactions is similar to a traditional transaction. The simplest example of a complex transaction is Nested Transactions [12].

Complex transactions are distinguishable from the *multilevel* transactions [13, 11, 1] first in that their internal structure is *explicit* and provided as a user facility, and second

in that their component transactions are not necessarily *atomic*. Multilevel transactions have an *implicit* hierarchical internal structure which is a result of transactions invoking operations on complex objects. Thus, the operations are decomposable into sub-operations. Both operations and sub-operations are considered atomic. That is, for the user, a multilevel transaction is nothing but a set of atomic operations similar to a traditional transaction, and nesting is provided as a system facility.

The way that component transactions are combined to form complex transactions reflects the semantics of the applications. Such semantics can be exploited in designing *transaction specific concurrency control* and *transaction specific recovery*. The idea is similar to the use of semantic information about the objects and their operations in designing *type specific concurrency control* to enhance concurrency within objects [2, 16, 9, 21].

*Transaction specific concurrency control* allows the definition of new weaker notions of conflicts among operations not possible with the information available only about objects and their types. For instance, operations invoked by two transactions can be interleaved as if they commuted, if the semantics of the application allow the dependencies between the transactions to be ignored. Clearly, transaction specific concurrency control might *not* achieve serializability but still preserves consistency. This seems to be an attractive means for increasing the performance in a complex information system.

*Transaction specific recovery* can be designed along the same lines to exploit the semantics of the application in order to minimize the effects of transactions failures. Transaction specific recovery reduces the cost of recovery by tolerating partial failures and by supporting both forward and backward recovery. In the event of failure of transaction components, the failed portions can be isolated, allowing the rest of the transaction to proceed. Failed portions of a transaction can be retried, compensated by attempting another alternative, or even ignored. Furthermore, complex transactions naturally support user-controlled checkpointing since the boundaries of component transactions act as checkpoints.

The above observations motivate us to address the following questions in our research:

- *How do we capture the semantics of complex transactions?*
- *How can we reason about the concurrency and recovery properties of complex transactions?*

The ACTA model described in the next section is our initial response to these questions.

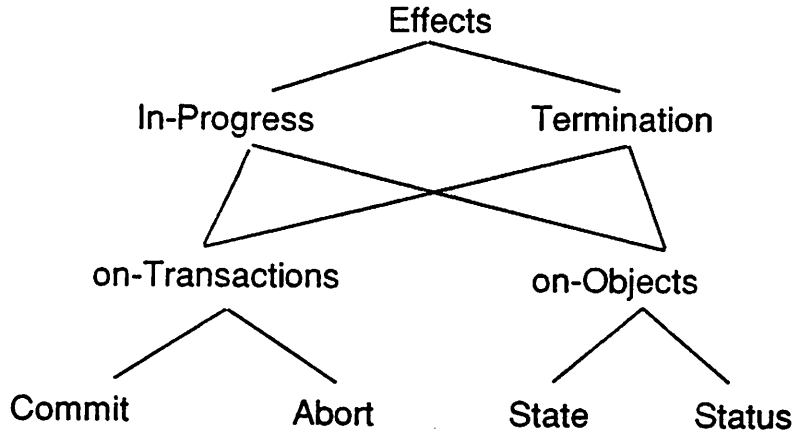

Figure 1: Dimensions of the ACTA Model

### 3 The ACTA Model

The behavior of a transaction system is determined by the behavior of its active components and the interactions among these components. The active components of our model are *transactions*, inherently parallel activities, and the passive components are *objects*, abstract entities manipulated by transactions.

Transactions may produce unexpected results if they interact indiscriminately. A correctness criterion for transactions constrains these interactions to those that produce a result contained in a set of acceptable results. In order to specify a correctness criterion that prevents some interactions from occurring while allowing others, we must be able to express these interactions. Interactions among transactions are reflected in the effects they cause and thus, we can express them in terms of these effects: We distinguish between transactions' effects on each other and transaction effects on the objects that they access.

A transaction has two possible outcomes, namely, commit or abort. Consequently the effects of one transaction on other transactions are classified as those *on the abort* of other transactions and those *on the commitment* of other transactions.

The effects of a transaction on the objects that it accesses are also categorized into two classes: The effects of a transaction on the *state* of objects and the effects of a transaction on the *concurrency status*, i.e., synchronization state, of objects. (Henceforth, we refer to concurrency status as just *status*).

By taking into account the fact that these effects of a transaction may occur both during the execution of the transaction and at the termination of the transaction, we further distinguish them as *in-progress effects* and *termination effects*. This taxonomy of effects is

captured in figure 1.

As we shall see, the framework allows us to capture transaction properties as related to the dimensions of (i) *visibility*, (ii) *failure atomicity (recovery)*, (iii) *permanence* and (iv) *consistency*.

### 3.1 Effects of Transactions on other Transactions

Dependencies provide a convenient way of specifying and reasoning about the behavior of concurrent transactions [8, 16]. By examining the possible effects of interacting transactions on each other, it is possible to determine the dependencies that may develop between the transactions. There are two possible dependencies that a transaction may develop on any other transaction: *Commit-dependency* and *abort-dependency*.

Commit-dependency and abort-dependency are collectively known as *completion dependencies* and are defined as follows:

**Commit-Dependency:** If a transaction  $A$  develops a *commit-dependency* on another transaction  $B$  (denoted by  $A \rightarrow B$ ), then transaction  $A$  cannot commit until transaction  $B$  either commits or aborts. This does not imply that if transaction  $B$  aborts, then transaction  $A$  should abort.

**Abort-Dependency:** If a transaction  $A$  develops an *abort-dependency* on another transaction  $B$  (denoted<sup>2</sup> by  $A \Rightarrow B$ ), and if transaction  $B$  aborts, then transaction  $A$  should also abort. This neither implies that if transaction  $B$  commits, then transaction  $A$  should commit, nor that if transaction  $A$  aborts, then transaction  $B$  should abort.

Commit-dependency and abort-dependency define a commit order which prevents transactions from prematurely committing, thereby preventing object inconsistencies, given that transactions preserve the consistency of the database when run in isolation. Depending on the transaction model and its correctness notion, some dependency cycles may lead to inconsistencies and hence, they are prohibited, whereas other dependency cycles are accommodated. In the latter case, if two transactions form a circular dependency involving the same type of completion dependency, then both have to commit or neither. In the case that

---

<sup>2</sup>The specific direction of the arrows for commit and abort dependencies is chosen for readability reasons. To reflect the required order of transactions' commitment, the arrows should be drawn in the opposite direction.



two transactions develop a circular dependency involving dependencies of different types, i.e., one transaction has a commit-dependency on another transaction which has an abort-dependency on the first transaction, then the commitment of both transactions must be synchronized. This does *not* imply that both transactions have to commit or neither as in the case above.

It is often necessary for dependencies induced by the structure of transactions to be qualified either to further strengthen them by attaching to them more restrictions, or to restrict the scope of their applicability by attaching conditions. As an example of the former, abort-dependency can be restricted so that a transaction is not allowed to develop an abort-dependency on more than one other transaction. This stronger version of abort-dependency is called *exclusive-abort-dependency* (denoted  $\overset{\neq}{\Rightarrow}$ ) and is useful in controlling the expansion of a complex transaction. As an example of restricting the scope of an abort-dependency, consider *weak-abort-dependency* where an abort-dependency between two transactions holds as long as *both* transactions are executing.

*Transitive-abort-dependency* (denoted by  $\overset{\neq}{\Rightarrow}$ ) is defined by the transitive closure of abort-dependencies. A transaction  $A$  has a transitive-abort-dependency on every member of the set of transactions formed by the transitive closure of abort-dependencies starting from  $A$ . *Transitive-commit-dependency* (denoted by  $\overset{\neq}{\rightarrow}$ ) is similarly defined.

Completion dependencies between transactions may be a direct result of the structural properties of the complex transaction formed by the interacting transactions, or may indirectly develop as a result of interactions of transactions over shared objects. Dependencies formed by the interactions over a shared object are specified by the *compatibility table* associated with the object and encodes the object's synchronization properties. In the traditional framework, a compatibility table is a simple a binary relation with a *yes* entry for  $(O_i, O_j)$  indicating that the operations  $O_i$  and  $O_j$  are compatible, i.e., do *not conflict*, or a *no* entry indicating that the two operations are incompatible, i.e., conflict. In our case, an entry  $(O_i, O_j)$  could be a *condition* involving completion dependencies, operation arguments and results. In particular, an entry could be *No-dependency*, i.e., the standard *yes* entry, *Form-Abort-Dependency*, *Form-Commit-Dependency*, *Wait*, i.e., the standard *no* entry, *Abort*, *Notify*, *Allow-if-Abort-Dependency-already-exists*, *Allow-if-Commit-Dependency-already-exists*, etc. While the other entries are self-explanatory, a *Notify* entry corresponding to  $(O_i, O_j)$  implies that transaction invoking  $O_j$  should be notified of  $O_i$ 's presence. This generality allows the framework to capture different types of type-specific concurrency control discussed in the

literature [16, 20, 9, 10, 2].

### 3.2 Effects of Transactions on Objects

Each object is characterized by its state and its status. The state of an object is represented by its contents. The status of an object is represented by the synchronization information associated with the object. Part of the synchronization information is the compatibility table that specifies the concurrency properties of the object, i.e. the rules for accessing the object [16, 20, 9, 10, 2]. In addition, our extension to the compatibility table, discussed in the last section, allows the specification of the formation of completion dependencies when operations execute. The state of an object changes when a transaction modifies the contents of the object. The status of an object changes when a transaction accesses the object.

Transactions' effects on objects are captured by the introduction of two sets, the *View Set* and the *Access Set*, and by the concept of *delegation*. Due to space limitation, here we just provide the intuition underlying these concepts. Their application to specify different transactions schemes such as Nested and Split Transactions, in the next section, will provide concrete forms to these concepts.

Transactions' effects on objects can be restricted by limiting the number of objects accessible to them. For this reason, every transaction is associated with a set of objects, called *View Set*, which contains all the objects potentially accessible to the transaction. Rules for composing the View Set are determined by the specific transaction model. Specific examples are given in Section 4.

The effects of a transaction on objects are conditional upon the outcome of the transaction. Objects actually accessed by the transaction are contained in another set, called *Access Set*. When a transaction *aborts*, the state and the status of all objects in the transaction's Access Set are restored in its View Set. When a transaction *commits*, the state of all objects in its Access Set is made persistent, i.e., the changes are effected, in the View Set, while the status is restored in the View Set.

A transaction may *delegate* the responsibility for finalizing its effects on some of the objects in its Access Set to another transaction. This is achieved by removing the delegated objects from the Access Set of the first transaction (*delegator*) and adding them to the Access Set of the second transaction (*delegatee*). That is, *delegation* represents the ability of a transaction to give up some of its objects which are then taken over by another transaction. Delegation effectively broadens the visibility of transactions and it is useful in selectively

making tentative or partial results as well as hints, such as, coordination information, accessible to other transactions.

The notion of delegation defined thus far is related to one of the two dimensions of objects, namely, the state, and thus is called *delegation of state*. There is another type of delegation related to the status of objects. This type of delegation is referred to as *delegation of status*. Delegation of status as opposed to delegation of state, implies that the changes done by the delegating transaction to the delegated objects are undone, before these objects are added to the Access Set of the delegatee. Effectively, the delegation of status represents the ability of one transaction to relinquish the control of the visibility of some of its objects to another transaction.

It is possible for a transaction to delegate some of its objects at termination time. Delegation at termination time is referred to as *inheritance*. Inheritance has three forms in accordance with the three possible termination conditions: *inherits at commit*, *inherits at abort* and *inherits at termination*, i.e., inherits at commit or abort. The form of inheritance can be further refined according to the specific type of delegation involved. The notion of inheritance used in Nested Transactions as proposed in [12] is similar to our first form of inheritance, whereas in [14] it is similar to our third form of inheritance. To be precise, the former case corresponds to the inheritance of state at commit, and the latter case corresponds to the inheritance of status at abort and inheritance of state at commit.

Another form of delegation is *limited delegation* which makes the changes to the delegated objects persistent in the View Set before adding them to the Access Set of the target transaction.

In cooperative environments, transactions (components) cooperate by having intersecting Access Sets and View Sets, by delegating objects to each other, or by *notifying* each other of their behavior. By being able to capture these aspects of transactions, the ACTA model is designed to be applicable to cooperative environments.

## 4 Modeling Different Transaction Schemes

In this section, the semantics of four transaction models are specified using the ACTA model, namely, Nested Transactions, Split Transactions, Recoverable Communicating Actions and Cooperative Transactions. Because of space limitations, the characterization of Transaction Groups [6, 18] and Multi-Coloured Actions [17] are not included in this paper. Also, the

properties of a new transaction model resulting from the combination of Nested Transactions and Split Transactions are studied in order to demonstrate the usefulness of our model in reasoning about the properties of existing and future transaction models.

#### 4.1 Nested Transactions

In the Nested Transaction model [12], transactions are composed of subtransactions or child transactions designed to localize failures within a transaction and to exploit parallelism within transactions. A subtransaction can be further decomposed into other subtransactions, and thus, the transaction may expand in a hierarchical manner. Subtransactions execute atomically with respect to their parent and their siblings, and can abort independently without causing the abortion of the whole transaction. However, if the parent transaction aborts, all its subtransactions have to abort. The parent transaction cannot commit until all its subtransactions have terminated.

A subtransaction can potentially access any object that is currently accessed by one of its ancestor transactions. In addition, any object in the database is also accessible to the subtransaction. When a subtransaction commits, its objects are made accessible to its parent transaction. However, the effects on the objects are made persistent in the database only when the root transaction commits.

Here is the characterization of Nested Transactions in the ACTA model. We use  $C$  to denote a child transaction of a parent transaction  $P$ .

##### In-Progress Effects:

- Dependency Specifications

- $\forall C, C \stackrel{e}{\Rightarrow} P$

- $\forall C, P \rightarrow C$

The abort-dependency of a child on its parent guarantees the abortion of the child transaction in the case that its parent aborts. Furthermore, the exclusive-abort-dependency prohibits a child transaction from having more than one parent; this ensures the hierarchical structure of the nested transactions.

The commit-dependency of the parent on its children guarantees that the parent does not commit before all its children have terminated.

- View Set Specifications<sup>3</sup>

$$- \forall C, \text{ViewSet}_C = \{\cup \text{AccessSet}_A | C \stackrel{=}{\Rightarrow} A\} \cup \{\text{System DB}\}$$

*System DB* stands for the system database.

The ability of a subtransaction to access any object currently accessed by one of its ancestor transactions is expressed by defining the View Set of the subtransaction in terms of the Access Sets of its ancestor transactions. The transitive-abort-dependency uniquely specifies the ancestors of a subtransaction.

**Termination Effects:**

- Delegation Specifications<sup>4</sup>

$$- \forall C, P \text{ inherits at commit from } C$$

The inheritance specification states that, at commit, the child transaction's objects are delegated to its parent transaction. This effectively makes the effects of the committing child transaction selectively visible to its parent and to the parent's descendants (by the visibility specification above).

## 4.2 Split Transactions

In the Split Transaction model [15], it is possible for a transaction  $A$  to split into two transactions,  $B$  and  $C$ , where  $B$  is the original transaction.  $B$  and  $C$  transactions may be *independent*, in which case they can commit or abort independently, or they may be *serial*, in which case  $B$  must commit in order for the  $C$  to commit. Whether  $B$  and  $C$  transactions are independent or serial depends on the objects accessible to them.

---

<sup>3</sup>In our notation,  $\cup$  is an *ordered union*. More precisely, if  $C = A \cup B$ , then  $C$  contains all the elements of  $A$  and  $B$  as in a set union. However, if there is an element in  $A$  duplicated in  $B$ ,  $C$  contains the element from  $A$ . We need this for the following reason. Suppose an object  $O$  in System DB is modified by  $P$  and is then accessed by  $R$ . Then only the modified version of  $O$  should be accessible to  $R$ . Note that this notion of versions is different from object versions maintained explicitly for application-dependent reasons. We propose to capture them latter by viewing such versions as different objects. Versions in the current situation exist only until the root transaction terminates.

<sup>4</sup>In the case of [14] the delegation specification should state in addition:  $\forall C, P$  inherits of status at abort from  $C$ .

### 4.2.1 Independent Split Transactions

Here is the characterization of *independent* Split Transactions in the ACTA model:

#### In-Progress Effects:

- Delegation Specifications
  - $A$  delegates objects in  $DelegateSet$  to  $B$  where:  
$$AccessSet_B = AccessSet_A - DelegateSet$$
$$AccessSet_C = DelegateSet$$

The independence of the two transactions is guaranteed by having  $B$  and  $C$  operate on disjoint sets of objects. Delegation leaves  $C$  the responsibility of making persistent all the changes made by  $A$  to delegated objects up to the split.

#### Termination Effects:

Independent transactions after the split behave like traditional transactions and so the termination of  $B$  and  $C$  have no effect on the other.

### 4.2.2 Serial Split Transactions

Now we characterize *Serial* Split Transactions which have more complicated semantics than independent Split Transactions.

#### In-Progress Effects:

- Dependency Specifications
  - $C \stackrel{x}{\Rightarrow} B$

The abort-dependency guarantees that transaction  $C$  aborts if  $B$  aborts and that  $C$ 's commitment is delayed until  $B$  commits. The exclusive-abort-dependency prevents  $C$  from joining (see below) a third transaction<sup>5</sup>. Note that this does not prevent transactions  $B$  and  $C$  from joining.

---

<sup>5</sup>This constraint can be removed if the *join* operation requires that the joint transaction develops the same dependencies as the joining transaction.

- View Set Specifications

Split Transactions were proposed in the context of the Read-Write database model. Hence the view sets of B and C can be specified in terms of the set of objects that they can read or write.

- $ViewWrite_B = ViewWrite_A$
- $ViewRead_B = ViewRead_A$
- $ViewWrite_C = \{x | x \in WriteSet_B \wedge C\_WriteLast(x)\} \cup \{System\ DB\}$
- $ViewRead_C = \{x | x \in WriteSet_B \wedge C\_CanRead(x)\} \cup \{System\ DB\}$

$WriteSet_B$  contains the objects that A has changed up to the split and may change after the split when executing as B. That is,  $WriteSet_B$  is a subset of the Access Set of A. The  $C\_WriteLast$  specifies the objects that can be updated last by C. Similarly,  $C\_CanRead$  specifies the objects that C can read but they are not delegated to C.

The  $ViewWrite_C$  ( $ViewRead_C$ ) contains all the objects that C can potentially write (read) after the split. In this way, some of the changes to the objects up to the time of the split become visible to C. Not delegating these objects to C ensures that the changes to the objects up to the split are not lost if C aborts<sup>6</sup>.

- Delegation Specifications

- A delegates objects in  $DelegateSet$  to C where
 
$$AccessSet_B = AccessSet_A - DelegateSet$$

$$AccessSet_C = DelegateSet$$

Any changes to objects in  $DelegateSet$  up to the split are left to C to be made persistent to the database.

### Termination Effects:

- Delegation Specifications

---

<sup>6</sup>Furthermore, in this way, B can regain access to these objects after the abortion of C. Note that this is not supported by the original notion of Split Transactions [15], although it might be appropriate for some applications.

- Limited delegation of objects in  $\text{DelegateSet}'$  occurs from  $B$  to  $C$ :

$$\text{DelegateSet}' = \text{AccessSet}_B \cap \text{ViewSet}_C$$

When  $B$  commits while  $C$  is still executing, it delegates limited responsibility of the objects to  $C$  that  $C$  could potentially access but it did not. In this way, all the changes to these objects are made persistent to the database while  $C$  still has access to these objects.

If  $B$  aborts then  $C$  is also aborted, given that  $C$  has an abort-dependency on  $B$ . All the objects acquired by both transactions are restored to the system.

By comparing the characterizations of the independent and serial split transaction in ACTA, one can infer that the source of the abort-dependency in the case of serial split transactions is due to the View Set specifications and in particular, to the information flow allowed by the View Set specifications. A closer study of the View Set specifications reveals that in the case that  $C$  is not allowed to read any object that is not delegated to it or is not in the database (i.e.,  $\text{ViewRead}_C = \{\text{SystemDB}\}$ ), the abort-dependency of  $C$  on  $B$  can be substituted by a commit-dependency which avoids cascading aborts while still ensuring serial commitment of  $B$  and  $C$ .

### 4.2.3 Joint Transactions

In the Split Transactions model, it is also possible for two transactions to join into one. This is called the *joint* transaction. The joint transaction is either of the original ones. When the transactions join, they release their objects to the joint transaction.

The characterization of Joint Transactions in the ACTA model is straight forward:

#### Termination Effects:

- Dependency Specification
  - Joining transaction  $\stackrel{z}{\Rightarrow}$  Joint transaction
- Delegation Specification
  - Joint transaction inherits at commit from Joining transaction.



### 4.3 Nested-Split Transactions

In order to test the reasoning capabilities of the framework, we created a new model by combining the Nested and Split Transaction models presented in the previous section. The framework was then used to check whether this new model retains the properties of the two original models.

Note that, given a nested transaction, it is possible to split a leaf node, an internal node, or a root node. The split nodes could execute independently or serially. Figure 2. captures the effects for all possible combinations. The dependencies shown follow from the specifications of dependencies for nested and split transactions. In these figures a *dotted arrow* denotes a commit-dependency and a *solid arrow* denotes an abort-dependency.

When a node, say  $C$  (figure 2b), splits into two subtransactions, say  $C1$  and  $C2$ , where  $C1$  is the original subtransaction  $C$ , the dependencies between subtransaction  $C$  and transaction  $A$  are assumed to hold between  $C2$  and  $A$ . Since both nested and split transactions involve exclusive-abort-dependencies (recall that exclusive-abort-dependency prevents a transaction from having an abort dependency on more than one other transaction), a node splitting may result in a subtransaction that has exclusive-abort-dependencies on two other subtransactions (figure 2b, After the Serial Split). Such inconsistencies may be resolved by means of consistency preserving rewrite rules. In general, consistency preserving re-write rules are used to simplify the structure of a complex transaction by eliminating redundant dependencies. Figure 2a shows four such rewrite rules of which *re-write 2* resolves the inconsistency mentioned above.

After applying the rewrite rules (in these cases only re-write 2 is applicable), we examine the remaining dependencies for each type of nested-split transaction to see if the resulting structure preserves the semantics of the Nested and Split transactions models. We conclude that in only one case the properties of the two models are preserved. This case involves the splitting of the leaf node into two independent subtransactions. In all other cases the model either establishes dependencies which destroy the structure of the nested transactions or eliminates some of the dependencies required by the nested transactions. For example, in figure 2b (After Applying Re-write Rule), the exclusive-abort-dependency of subtransaction  $C2$  on subtransaction  $A$  is eliminated.

Even if splitting of nodes is restricted only to the independent splitting of leaf nodes, nested-split transactions is a useful new transaction model in a cooperative environment.

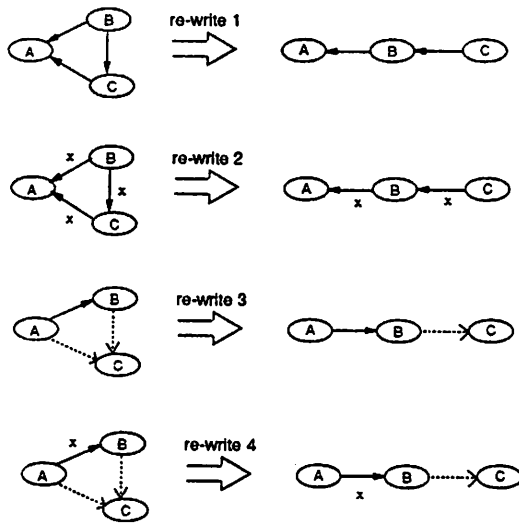

a. Semantics-preserving Re-Write Rules

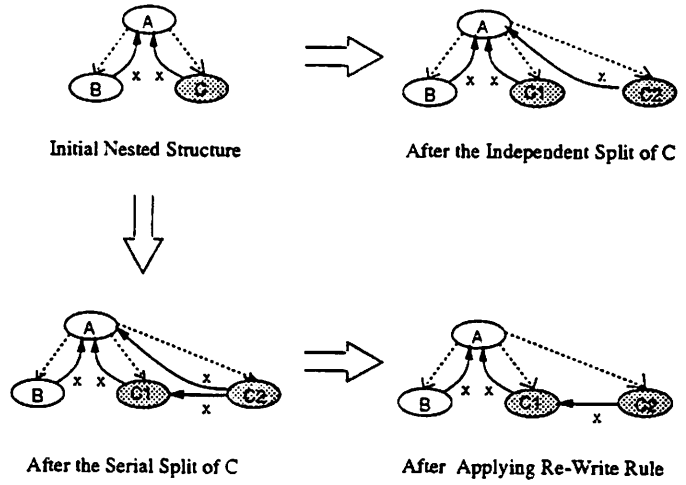

b. Splitting Leaf Node

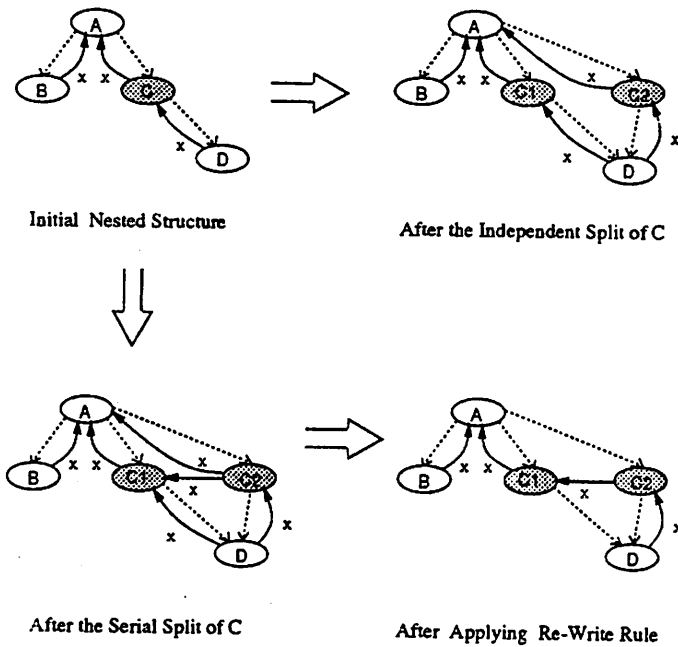

c. Splitting Internal Node

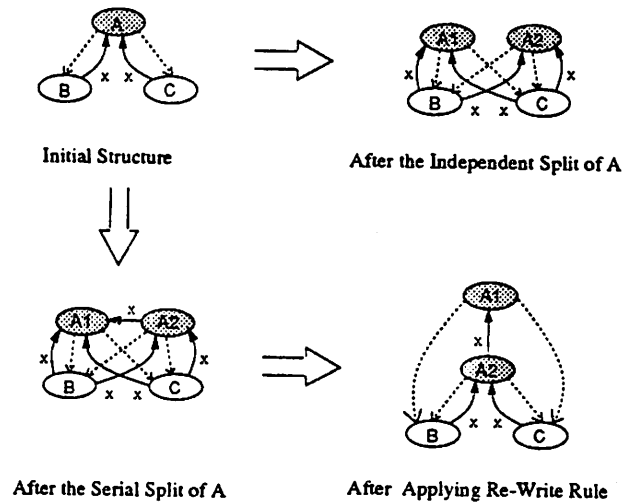

d. Splitting Root Node

Figure 2: Splitting a Nested Transaction

Observe that an internal node becomes a leaf node any time that it has no active child sub-transactions. That is, in nested-split transactions, a node may split at any point after all its child subtransactions have terminated and before activating any new subtransactions. For example, in figure 2c (Initial Nested Structure), when subtransaction *D* terminates, node *C* can be split into two independent subtransactions *C1* and *C2* as in figure 2b (After the Independent Split of *C*). *C1* may continue the execution of *C* spawning new subtransactions, while *C2* may commit delegating its objects to *A*. Since all the objects accessible to *A* are potentially accessible to all of its descendants (by View Set specifications of nested transactions), the objects delegated to *A* by *C2* are potentially accessible to *B*. This effectively achieves cooperation between the original siblings *C* and *B* while they are still executing. In nested transactions, two siblings cannot cooperate while both siblings are active, since subtransactions delegate their objects to their parent only at commit time. Thus, nested-split transactions support higher level of visibility between subtransactions than nested transactions do.

This exercise showed us the efficacy of the ACTA model in determining the properties of new transaction models, in this case, one derived by combining existing models.

#### 4.4 Recoverable Communicating Actions

In the context of long and cooperative transactions, the *Recoverable Communicating Actions (RCA)* model has been proposed to deal with the problem of non hierarchical computations [19]. In this model, an action, the *sender*, is allowed to communicate with another action, the *receiver*, by exchanging objects, resulting in an *abort-dependency* of the receiver on the sender. If the sender aborts then the receiver must abort as a result of the dependency.

By developing abort-dependencies, RCAs form a *recoverable computation* a self-contained task or activity which has the semantics of an atomic update. For this reason, actions belonging to the same recoverable computation require synchronized commitment. That is, even in the case of a sender which has no dependencies on any other action, the sender cannot commit independently. However, partial failures are tolerated since an action may abort without aborting the action with which it has developed an abort-dependency. In short, a recoverable computation can dynamically expand through the development of dependencies and shrink due to abortion of actions.

Here is the characterization of RCAs in ACTA:

### In-Progress Effects:

- Dependency Specifications
  - $Receiver \Rightarrow Sender$
  - $Sender \rightarrow Receiver$

The circular dependency involving different completion dependencies between sender and receiver guarantees the required synchronized commitment of the sender and receiver actions.

The abort-dependency guarantees that the effects of aborted actions are not reflected in the database. Neither the abort nor the commit dependencies prevent an action from developing any new dependencies. It is even possible for an action to be both a sender and a receiver at the same time. In this manner, RCAs can produce non-hierarchical structures.

- View Set Specifications

$$- \text{ViewSet}_{Receiver} = \{x \mid \text{Exchanged}(x)\} \cup \text{ViewSet}'_{Receiver}$$

Primed sets denote old sets and unprimed sets denote new sets.  $\text{Exchanged}(x)$  specifies that the sender transfers object  $x$  to the receiver, where,  $x \in \text{AccessSet}_{sender}$ .

Given the complete characterization of Split and RCA models in ACTA, one can immediately observe that the two models involve different completion dependencies. This difference is sufficient to demonstrate that one model does not subsume the other. Another difference is that the notion of delegation does not exist in RCAs. Just as in the case of nested-split transactions, using ACTA is easy to demonstrate that in spite these differences the two models are compatible, in the sense that it is possible to combine and use them.

### 4.5 Cooperative Transactions

Cooperative Transactions [3] were proposed in the context of CAD/CAM and design applications supported by the checkin/checkout access date model. In the Cooperative Transaction model, transactions are decomposed into subtransactions, each with its own semantics and types. The model supports three distinct types of subtransactions: *project* transactions are

decomposed into cooperative transactions; *cooperative* transactions are composed of a set of subcontractor transactions; and *subcontractor* transactions may either have a structure similar to cooperative transactions in which case the *client* cooperative transaction acts as a local project transaction, or have the structure of an atomic transaction called *short* transactions.

Cooperative transactions have a hierarchical structure similar to nested transactions, but they do not support object inheritance in the same manner as in nested transactions. In cooperative transactions object flow is supported only between adjacent levels through intermediate *semi-public* or *subcontractor* databases. This does not imply that the transactions are prevented from accessing objects in the database. A semi-public database is similar to a subset of an Access Set in the ACTA model.

The characterization of cooperative transactions in the ACTA model is very close to the one for nested transactions due to the similarities in their structures. A Project transaction corresponds to the root or top transaction in the nested transaction model.

#### In-Progress Effects:

For short, we use *coop* to denote a cooperative transaction and *contractor* to denote a subcontractor transaction. We also use subscripts to denote the components or children transactions of a transaction. For example, *short<sub>ij</sub>* refers to the *j*th child of the *i*th cooperative transaction which is of type short.

- Dependency Specifications

- $\forall i, Coop_i \stackrel{\pm}{\Rightarrow} Project$
- $\forall i, Project \rightarrow Coop_i$
- $\forall i, j, Contractor_{ij} \stackrel{\pm}{\Rightarrow} (client) Coop_i$
- $\forall i, j, (client) Coop_i \rightarrow Contractor_{ij}$
- $\forall i, j, Short_{ij} \stackrel{\pm}{\Rightarrow} Coop_i$
- $\forall i, j, Coop_i \rightarrow short_{ij}$

The hierarchical structure of cooperative transactions is expressed using the universally quantified completion dependencies.

Cooperative transactions also support situations in which there is a partial ordering that constrains the acceptable orderings of subcontractor and short transactions executions. These situations can be easily expressed via commit-dependencies in ACTA.

For example, if the 3rd subcontractor of the  $i$ th cooperative transaction should happen before the 4th one, these semantics can be specified as:

$$Contractor_{i4} \rightarrow Contractor_{i3}$$

- View Set Specifications

- $ViewSet_{Project} = \{System\ DB\}$
- $ViewSet_{Coop} = \{AccessSet_{Project} | Coop \Rightarrow Project\} \cup \{System\ DB\}$
- $ViewSet_{Short} = \{DesignersSet_{Coop} | Short \Rightarrow Coop\} \cup \{System\ DB\}$
- $ViewSet_{Contractor} = \{ContractorsSet_{Coop} | Contractor \Rightarrow Coop\} \cup \{System\ DB\}$
- $AccessSet_{Coop} = DesignersSet_{Coop} \cup ContractorsSet_{Coop}$
- $DesignersSet_{Coop} \cap ContractorsSet_{Coop} = \emptyset$

Objects in the DesignersSet can only be moved to ContractorsSet and vice versa by the cooperative transaction whose Access Set is formed by these sets.

The View Set definitions of the short and subcontractor transactions specify that these transactions can only access objects currently accessed by their parent transaction. The View Sets of the short and subcontractor transactions are further constrained to be the DesignersSet and ContractorsSet respectively. That is, the View set of a short transaction is the DesignersSet, a subset of the Access Set of its parent cooperative transaction. The View Set of a subcontractor transaction is the ContractorsSet, a subset of the Access Set of its parent cooperative transaction.

**Termination Effects:**

- Delegation Specifications

- $\forall i, Project$  inherits at commit from  $Coop_i$
- $\forall i, Project$  inherits (status) at abort from  $Coop_i$
- $\forall i, j, Coop_i$  inherits at commit from  $Short_{ij}$
- $\forall i, j, Coop_i$  inherits (status) at abort from  $Short_{ij}$
- $\forall i, j, Coop_i$  inherits at commit from  $Contractor_{ij}$
- $\forall i, j, Coop_i$  inherits (status) at abort from  $Contractor_{ij}$

As in the case of nested transactions, the delegation specification states that at commit, the child (cooperative, short, or subcontractor) transaction's objects are delegated to its parent (project, or cooperative) transaction. However, in the case of short and subcontractor transactions the delegated objects are added to the respective *DesignersSet* and *ConstructorsSet* (by the visibility specification above). This effectively makes the effects of the committing child transaction selectively visible to its parent, and forces the parent's short transactions to cooperate through the objects contained in the *DesignersSet* and the parent's subcontractors to cooperate through objects in the *ConstructorsSets*.

In the case of abort, the child transaction's objects are delegated to its parent after the state changes done by the child on the objects are nullified.

## 5 Conclusion

ACTA, the comprehensive transaction model proposed in this paper, captures the spectrum of interactions among transactions in competitive and cooperative environments. Each point within the space of interactions is expressed in terms of transactions' effects on the commit and abort of other transactions and on objects' state and concurrency status (i.e., synchronization state).

ACTA allows for specifying the *structure* and the *behavior* of transactions as well as for reasoning about the concurrency and recovery properties of the transactions. The ACTA model is *not* yet another transaction model, but is intended to unify the existing models. Its ability to capture the semantics of previously proposed transaction models is indicative of its generality. The reasoning capabilities of this framework have also been demonstrated by using the framework to study the properties of a new model that is derived by combining the Nested and Split transaction models.

We are currently investigating a formalism that will allow us to precisely characterize the correctness properties of a set of transactions or a transaction model. Such a model will, for example, allow us to determine whether or not the given model produces only serializable computations, and if not, whether the computations are *consistency preserving*, i.e., whether the interactions in the computations do not conflict in such a manner as to produce object inconsistencies.

In order to explore the practical impact of being able to develop new transaction

models using this framework, we are also examining the development of a canonical model for implementing object managers and transaction managers to design type specific and application specific concurrency control and recovery mechanisms.

Overall, we believe that our framework will lead to a better understanding of the nature of interactions between transactions and the effect of transactions in environments that require transaction models that are not supported well by the traditional transaction model. Further, with the proposed framework, it should be possible to precisely specify the type of interactions and effects allowable in a particular application, and explore ways for achieving cooperation. The concurrency and recovery properties of transactions in the given application can then be studied using the reasoning capabilities built into the framework. Finally, by including an examination of the implementation mechanisms required to support complex transactions within its purview, our work also intends to provide answers concerning the increased complexity entailed by the improved flexibility in constructing complex transaction models.

## References

- [1] Badrinath, B. Concurrency control in complex information systems: A semantics-based approach. Phd thesis. Univeristy of Massachusetts, Amherst, MA., August 1989.
- [2] Badrinath, B. and Ramamritham, K. Semantics-based concurrency control: Beyond Commutativity. In *Fourth IEEE Conference on Data Engineering*, pages 132-140, February 1987.
- [3] Bancilhon, F., Kim, W., and Korth, H. A model of CAD Transactions. In *Proceedings of the 11th international conference on VLDB*, pages 25-33, Stockholm, August 1985.
- [4] Chrysanthis, P. K. and Ramamritham, K. Capturing the structure and the behavior of complex transactions. In *Proceedings of the Third Workshop on Large Grain Parallelism*, SEI, Carnegie Mellon University, Pittsburgh, October 1989.
- [5] Eswaran, K., Gray, J., Lorie, R., and Traiger, I. The notion of consistency and predicate locks in a database system. *Communications of the ACM*, 19(11):624-633, November 1976.
- [6] Fernandez, M. and Zdonik, S. Transaction groups: A model for controlling cooperative transactions. In *Workshop on Persistent Object Systems: Their Design, Implementation and Use*, pages 128-138, January 1989.
- [7] Gray, J. The transaction concept: Virtues and limitations. In *Proceedings of the 7th VLDB Conference*, pages 144-154, September 1981.



- [8] Gray, J. N., Lorie, R. A., Putzulo, G. R., and Traiger, I. L. Granularity of locks and degrees of consistency in a shared database. In *Proceedings of the 1st international conference on VLDB*, pages 25–33, Framingham, MA., September 1975.
- [9] Herlihy, M. P. Extending multiversion timestamping protocols to exploit type information. *IEEE Transactions on Computers*, 35(4):443–449, April 1987.
- [10] Herlihy, M. P. and Weihl, W. Hybrid concurrency control for abstract data types. In *Proceedings of the 7th ACM symposium on Principles of Database Systems*, pages 201–210, March 1988.
- [11] Martin, B. E. Scheduling protocols for nested objects. Technical Report CS-094, Department of Computer Science and Engineering, University of California, San Diego, California. 1988.
- [12] Moss, J. E. B. Nested Transactions: An approach to reliable distributed computing. PhD thesis 260, Massachusetts Institute of Technology, Cambridge, MA, April 1981.
- [13] Moss, J. E. B., Griffith, N., and Graham, M. Abstraction in recovery management. In *Proceedings of the ACM SIGMOD international conference on management of data*, pages 72–83, May 1986.
- [14] Pu, C. *Replication and Nested Transactions in the Eden Distributed System*. PhD thesis, University of Washington, 1986.
- [15] Pu, C., Kaiser, G., and Hutchinson, N. Split-Transactions for Open-Ended activities. In *Proceedings of the 14th international conference on VLDB*, pages 26–37, Los Angeles, California, September 1988.
- [16] Schwarz, P. M. and Spector, A. Z. Synchronizing shared abstract data types. *ACM Transactions on Computer Systems*, 2(3):223–250, August 1984.
- [17] Shrivastava, S. K. and Wheeler, S. M. Objects and multi-coloured actions. In *Third Workshop on Large Grain Parallelism*. SEI, Carnegie Mellon University, Pittsburgh, October 1989.
- [18] Skarra, A. and Zdonik, S. Concurrency Control and Object-Oriented Databases. In *Object-Oriented Concepts, Databases, and Applications*, pages 395–421. ACM Press, 1989.
- [19] Vinter, S., Ramamritham, K., and Stemple, D. Recoverable actions in gutenber. In *Proceedings of the Sixth International conference on Distributed Computing Systems*, pages 242–249, May 1986.
- [20] Weihl, W. Specification and implementation of atomic data types. PhD Thesis MIT/LCS/TR-314, Massachusetts Institute of Technology, 545 Technology Square, Cambridge, MA., March 1984.
- [21] Weihl, W. Commutativity-Based concurrency control for abstract data types. *IEEE Transactions on Computers*, 37(12):1488–1505, December 1988.